

ELECTRIC SERVICE RULES AND REGULATIONS

Electricity



Water



Table of Contents

Introduction	1
Section 100 – Definitions	3
Section 200 – General Information	7
201 – Service Jurisdiction	7
202 – Agreement for Service	7
203 – Customer Information and Electrical Load Data Information	7
204 – Ownership of Equipment	7
204.1 MPS-Owned Equipment	7
204.2 Customer-Owned Equipment.....	8
204.3 Owner Responsibility	9
205 – Easements	9
206 – Inspection of Customer’s Facilities.....	9
206.1 – Installation Standard	9
206.2 – State Electrical Inspector.....	9
207 – Service Connection, Disconnection, and Reconnection	9
207.1 – Service Connection	9
207.2 – Disconnection or Reconnection.....	9
207.3 – MPS Employees Only	9
208 – Liability	9
209 – Service Interruption.....	10
210 – Unauthorized Use of Electricity	10
210.1 – MPS Mission	10
210.2 – Submetering is Illegal.....	10
211 – Pole Attachments	10
212 – Access.....	10
213 – Customer Responsibility	10
214 – Revisions of Requirements	10
215 – Damages to MPS Equipment.....	10
Section 300 – Rates, Deposits, and Connection Charges	11
301 – Rate Schedule Classifications	11

302 – Payment for Service	11
303 –Minimum Bill	11
304 – Service Extension Costs	11
304.1 – New Subdivision Infrastructure Costs	11
304.2 – New Subdivision Electric Buyout Costs.....	11
305 – Service Disconnection and Reconnection.....	12
305.1 – Service May Be Disconnected with Notice	12
305.2 – Service May Be Disconnected without Notice	12
305.3 – Reconnection Fee.....	12
306 – Service Deposits.....	12
307 – Collection of Past Due Accounts.....	12
308 – Charges for Line Extensions.....	12
Section 400 – Standard Services.....	13
401 – General Characteristics	13
402 – Availability of Service	13
403 – Secondary Service Voltages.....	13
403.1 – Single-Phase Service	13
403.2 – Three-Phase Service	13
404 – Primary Service Voltages.....	13
405 – Transmission Service Voltages.....	13
Section 500 – Special Services	15
501 – Temporary Service	15
501.1 – Availability	15
501.2 – Requirements	15
501.3 – Customer Equipment.....	15
501.4 – Charges for Temporary Service	15
502 – Services for Unusual Load Characteristics	15
503 – Redundant Facilities	15
504 – Relocation or Protection of MPS Facilities	16
505 – Security Lighting	16
506 – Underground Locations	16
507 – Dual-Fuel Program	16
507.1 – Availability	16

507.2 – Application for Service	16
507.3 – Heating System	16
507.4 – Heat Pumps.....	16
507.5 – Radiant Floor Heat.....	17
507.6 – Thermostat	17
507.7 – Customer Bypass Switch.....	17
507.8 – Metering Requirements	17
507.9 – Equipment Furnished by MPS	17
507.10 – Equipment Furnished by the Customer.....	17
507.11 – Equipment Installation	17
507.12 – Dual-Fuel Control Unit	17
507.13 – Control Wiring.....	17
507.14 – Affidavit.....	17
507.15 – Inspection by MPS.....	17
507.16 – Electric Storage Water Heaters.....	18
507.17 – Central Air Conditioners.....	18
507.18 – Other Qualifying Loads	18
507.19 – Non-Qualifying Loads	18
507.20 – Customer Bypass Switch.....	18
507.21 – Maintenance of Equipment	18
507.22 – Tampering	18
507.23 – Liability	18
507.24 – Multiple Dwelling Residences and Commercial Dual Fuel.....	18
507.25 – Customers Moving into a Home with Dual Fuel	18
507.26 – Ending Participation in the Program.....	19
508 – Interruptible Service Program	19
508.1 – Availability	19
508.2 – Application for Service	19
508.3 – Eligible Equipment for Curtailable Loads	19
508.4 – Eligible Equipment for Customer Generation	19
508.5 – Metering Requirements	19
508.6 – Equipment Installation	19
508.7 – Billing Credit	19

508.8 – Duration of Load Control.....	19
508.9 – Inspection	19
508.10 – Verification of Load Control.....	20
508.11 – Failure to Control Electric Load.....	20
508.12 – Changes to Operations or Equipment.....	20
508.13 – Ending Participation in Program.....	20
509 – Aggregation of Retail Customer Demand Response.....	20
510 – Ancillary Services Provided by Demand Response Resources.....	20
Section 600 – Meters.....	21
601 – Responsibilities for Providing Metering Equipment	21
601.1 – MPS’ Responsibilities	21
601.2 – Customer’s Responsibilities	21
602 – Capacity of Service.....	21
603 – Remote Water Meter Register	21
604 – Location of Meters	21
604.1 – Residential.....	21
604.2 Multiple Dwellings	22
604.3 – Industrial and Commercial	22
604.4 – Height Limits.....	22
604.5 – Mobile Homes.....	22
604.6 – Meter Clearance	22
604.7 – Access to Meters	22
605 – Grouped Meters.....	22
606 – Meter Identification	22
607 – Meter Mounting.....	23
607.1 – Outdoor Meters.....	23
607.2 – Indoor Meters	23
608 – Meter Connections.....	23
609 – Wiring Restrictions on Meters and Metering Sets	23
610 – Meter Testing.....	23
610.1 – Request for Meter Testing	23
610.2 – Bill Recalculation	23
610.3 – Duration of Inaccurate Measurement.....	23

610.4 – Failure of Equipment.....	23
611 – Meter Seals and Tampering.....	24
612 – Instrument Transformer Installation	24
612.1 – Underground Service from Pad-Mounted Transformers.....	24
612.2 – Metering Conduit	24
612.3 – Current Transformer Cabinets	24
612.4 – Transition Cabinets.....	24
612.5 – Overhead Service	24
612.6 – Overhead Service Entrance Conductors to Multiple Customers.....	24
Section 700 – Customer Utilization Equipment.....	25
701 – Motor Protection Devices.....	25
702 – Motor Starting Currents	25
703 – Power Factor	25
704 – Fault Currents.....	25
705 – Wiring Adequacy	26
706 – Customer-Owned Generating Equipment.....	26
707 – Energy Conservation	26
708 – Cogeneration Rules	26
709 – Harmonics and Voltage Distortion.....	26
709.1 – Voltage Flicker.....	26
Section 800 – Overhead Secondary Service	29
801 – Maximum Transformer Size.....	29
801.1 – Transformer Size	29
801.2 – Secondary Services.....	29
802 – Service Drop Conductors.....	29
802.1 – New Services.....	29
802.2 – Existing Services	29
803 – Clearances	29
803.1 – Minimum Clearance.....	29
803.2 – Installation Restrictions.....	29
804 – Point of Attachment	29
805 – Service Entrance	30
806 – Electric Distribution Converted from Overhead to Underground Distribution	30

Section 900 – Underground Service	31
901 – Undergrounding in New Residential Developments	31
901.1 – Availability	31
901.2 – Requirements	31
901.3 – Point of Demarcation	31
901.4 – Easements	31
902 – Residential Undergrounding in Overhead Areas	31
903 – Underground Service to Commercial and Industrial Customers	32
903.1 – Availability	32
903.2 – Junction Point	32
903.3 – MPS Ownership	32
903.4 – Primary Cable Installation	32
903.5 – Transformer Pads	32
903.6 – Responsibilities	32
903.7 – Meter Set	32
903.8 – Underground Service Extension	32
904 – Transformer Clearances	32
905 – Winter Installation	32
906 – Total Undergrounding	33
Section 1000 – Appendices	35
Dual-Fuel Residential Application	37
Dual-Fuel Commercial Application	39
Dual-Fuel Agreement	41
Appendix 2 – Exhibits	
Exhibit 1 – Typical Underground Residential Metering Arrangement	43
Exhibit 2 – Typical Mobile Home Metering Arrangement	44
Exhibit 3 – Typical Multiple Metering Arrangement	45
Exhibit 4 – Secondary Service Drop Clearances	46
Exhibit 5 – Typical Residential Overhead Installation	47
Exhibit 6 – Typical Residential Service Mast	48
Exhibit 7 – Location of Pad-Mounted Transformers Near Buildings	49
Exhibit 8 – Dual-Heating Metering	51



ELECTRIC SERVICE RULES AND REGULATIONS

Effective: February 17, 2026

INTRODUCTION

Moorhead Public Service (MPS) has assembled this booklet to assist its Customers and their architects, engineers, or electrical contractors to plan for and obtain prompt and satisfactory electric service.

The information presented here is intended to supplement the requirements of the National Electrical Code and all other applicable federal, state, and municipal codes, regulations, laws, and ordinances. It is always necessary to refer to, and comply with, such other codes, regulations, laws, and ordinances when planning, designing, and installing a new electrical service. Specific requirements of MPS' Electric Service Rules and Regulations do not intentionally conflict with any other requirements known to be in effect as of the effective date of this booklet. Any apparent conflicts of this nature should be brought to the attention of MPS' Electric Division staff for interpretation.

MPS wishes to serve its Customers promptly and satisfactorily. We will cooperate with Customers and their authorized representatives to the fullest extent in completing service connections with as little delay and inconvenience as possible, and will gladly give special attention to any particularly difficult situation confronting a Customer.

MPS will be happy to confer with those Customers requesting information about rates and services upon request. Such requests should be directed to an MPS Customer Accounts Specialist located at MPS' Business Office, MPS' website, or call (218) 477-8000.

**MOORHEAD PUBLIC SERVICE COMMISSION
CITY OF MOORHEAD, MINNESOTA**

SECTION 100

DEFINITIONS

Application for Service: The agreement or contract between MPS and the Customer under which electric service is supplied and taken.

Accessible: Admitting close approach, that is, not guarded by locked doors, elevation, or other effective means.

Approved: Acceptable to the authority having jurisdiction.

Connected Load: The combined manufacturer's rated capacity of all motors and other electric energy-consuming devices on the Customer's premises, which may, at the will of the Customer, be operated with the electric energy to be supplied from the service of MPS.

Customer: Any individual, partnership, corporation, or other legal entity now being served, or to be served, using the electric service of MPS at any specified location.

Customer's Service Equipment: The necessary equipment and accessories, located near the point of entrance of supply conductors to a building, which constitute the main control and means of disconnecting the supply to that building. This equipment usually consists of a circuit breaker or a switch and fuses.

Demarcation Point: The point of connection between MPS and the Customer.

Disconnection Means: A device, or group of devices, or other means by which the conductors of a circuit can be disconnected from their source of supply.

Distribution Lines: MPS' lines located along streets, alleys, highways, or easements on private property, when used or intended for general distribution of electric service to Customers of MPS.

Dwelling Unit: One or more rooms for the use of one or more persons as a housekeeping unit with space for eating, living, and sleeping and permanent provisions for cooking and sanitation.

One-Family Dwelling: A building consisting solely of one dwelling unit.

Two-Family Dwelling: A building consisting solely of two dwelling units.

Multi-Family Dwelling: A building containing three or more dwelling units.

Easement: A right to cross or otherwise use someone else's land for a specified purpose.

Electric Service: The availability of electric power and energy, regardless of whether any electric power and energy is actually used. The supplying of electric service by MPS consists of maintaining approximately the agreed voltage, phase and frequency, at the point of delivery, by means of facilities adequate for carrying the load for which MPS is thereby obligated to supply by reason of the known requirements.

Fault Current: The current that will flow through the system to a point where a piece of equipment or a conductor has failed, such as bare conductors touching together or a bare conductor touching a ground point.

MPS: Moorhead Public Service.

Meter Set: An instrument, or instruments, together with auxiliary equipment, for measuring the electric power and energy supplied to a Customer.

National Electrical Code: The current edition of the National Electrical Code as issued by the National Fire Protection Association.

National Electrical Safety Code: The current edition of the National Electrical Safety Code as issued by the American National Standards Institute.

Overhead Distribution Areas: The area or areas served by MPS' overhead distribution system as differentiated from the underground systems.

Point of Delivery: The point where the electric energy first leaves the line or apparatus owned by MPS and enters the line or apparatus owned by the Customer unless specified in the Customer's Agreement for Service. This is not necessarily the point of location of the MPS meter.

Rate Schedule Classification: The classification of the use of electricity into categories considering the amount of power supplied and the purpose of its use.

Secondary Terminal: The secondary side of a pad-mounted transformer, a secondary terminal box at the base of a riser pole, or a secondary junction box, whichever is designated by MPS.

Service: The conductors and equipment for delivering energy from MPS' system to the wiring system of the Customer.

Service Drop: The overhead service conductors from the last pole or other aerial support to and including the splices if any connecting to the service entrance conductors at the building or other structure.

Service Entrance Conductors, Overhead System: The service conductors between the terminals of the service equipment and a point usually outside the building, clear of building walls, where joined by tap or splice to the service drop.

Service Entrance Conductors, Underground System: The service conductors between the terminals of the service equipment and the point of connection to the service lateral.

Service Equipment: The necessary equipment, usually consisting of a circuit breaker or switch and fuses, and their accessories, located near the point of entrance of supply conductors to a building or other structure, or an otherwise defined area, and intended to constitute the main control and means of cutoff of the supply.

Service Lateral: The underground service conductors from the MPS distribution system, including any risers at a pole or other structure or from transformers to the first point of connection with the service entrance conductors in a terminal box or meter or other enclosures with adequate space, inside or outside the building wall. Where there is no terminal box, meter, or other enclosure with adequate space, the point of connection shall be considered to be the point of entrance of the service conductors into the building.

Type of Service: The characteristics of electric service described in terms of frequency, phase, nominal system voltage, and number of wires.

Transmission Service: Any type of service with a nominal voltage greater than or equal to 115,000 volts.

Primary Service: Any type of service with a nominal voltage between 600 volts and 12,470 volts.

Secondary Service: Any type of service with nominal voltage less than or equal to 600 volts.

Underground Residential Distribution (URD) Areas: Those residential subdivisions or other specified areas within which all Customers are served by underground distribution lines.

Voltage, Circuit: The greatest root-mean-square, effective, difference of potential between any two conductors of the circuit concerned.

Voltage, Nominal: The value, expressed in volts, which is assigned to a circuit or system for the purpose of conveniently designating its voltage class, for example, 120/240, 480Y/277, 600, etc. The actual voltage at which a circuit operates can vary from the nominal within a range that permits satisfactory operation of equipment.

Voltage to Ground: For grounded circuits, the voltage between the given conductor and that point or conductor of the circuit that is grounded. For ungrounded circuits, the greatest voltage between the given conductor and any other conductor of the circuit.

SECTION 200

GENERAL INFORMATION

201 Service Jurisdiction

The Moorhead Public Service Commission (Commission) provides electric services to all customers within Moorhead Public Service (MPS) service territory as defined by the Minnesota Public Utilities Commission, City of Moorhead (City) corporate boundaries, or to property owned by the City. Electric service may be provided to customers outside these boundaries, on a case-by-case basis, as approved by the Commission, and other necessary entities.

Electric utility improvements shall conform to MPS' Electric Service Rules and Regulations, City Codes, State law, and National Codes.

Any developer, entity, or owner, or other party that requests electric service extensions must formally petition the Commission and Moorhead City Council (Council). Petitions must be signed by the owner(s) of the property.

Before the improvement petition is approved, the petitioner may be asked to agree to any number of conditions that may include: preparation of plans and specifications; annexation; hook-up fees; all easements for placement, installation and servicing; agreeing to meet various codes and regulations, and other related conditions which the City and MPS may impose.

All utility improvements installed shall be in accordance with the specifications approved by the Commission and shall be done under the supervision of authorized MPS personnel.

202 Agreement for Service

Unless by special permission, MPS will supply to a Customer, at any specific premises, only one of the types of services listed in Section 400. The Customer must understand the requirements for Service whenever MPS requires a Customer payment in advance for the service(s) to be provided. A separate understanding of the requirements for Service is generally required for each type of service to be provided. The Customer's installation is to be arranged so that all electric service(s) under one understanding of the requirements for Service can be supplied at one point of delivery and measured by one metering set. The understanding of the requirements for Service are placed throughout the MPS' Electric Service Rules and Regulation.

203 Customer Information and Electrical Load Data Information

A Customer Information and Electrical Load Data Information (Information) specifies the type of service required by the Customer and expected magnitudes of connected and peak load. Additional data in the form of construction drawings and the proposed service entrance may also be necessary for MPS to adequately determine the capacity and arrangement of service to the Customer. The information must be received by MPS before a work order for the project can be issued and the necessary planning and design of the project can begin.

204 Ownership of Equipment

204.1 MPS-Owned Equipment. The meter and associated metering equipment furnished or installed by MPS are the property of MPS.

- (1) Overhead Distribution.

- (a) Overhead Service. In addition to the metering equipment, the overhead service drop installed by MPS is the property of MPS.
 - (b) Underground Service. MPS shall not own any of the secondary service equipment required. MPS may provide up to 250 kcmil aluminum Type USE cable for the Customer to install for conversion from an overhead to an underground service.
- (2) Overhead Distribution Converted to Underground Distribution.
- (a) Overhead Service. In addition to the metering equipment, the overhead service drop installed by MPS is the property of MPS.
 - (b) Underground Service. In addition to the metering equipment, for all installations requiring less than or equal to a single 250 kcmil aluminum triplex cable, MPS will own the secondary cable as described in Section 806.
- (3) Underground Distribution.
- (a) Overhead Service. In an underground distribution area, overhead services are not allowed.
 - (b) Underground Service. In addition to the metering equipment, for all installations requiring less than or equal to a single 250 kcmil aluminum triplex cable, MPS will own the secondary cable.

204.2 Customer-Owned Equipment. The meter socket, the service entrance conductors and conduit from the meter socket to the service entrance disconnect, the service entrance switch or circuit breaker, and the service entrance ground equipment are the property of the Customer. Exception: MPS provides the meter socket for installations requiring current transformers.

- (1) Overhead Distribution.
- (a) Overhead Service. In addition to the equipment on the Customer's side of the metering equipment, the service drop wire holder or bracket, the weatherhead and either the service mast and conduit with entrance wires or the service entrance cable with watertight connection to the metering equipment are the property of the Customer.
 - (b) Underground Service. In addition to the equipment on the Customer's side of the metering equipment, the Customer shall own all secondary wire and riser equipment.
- (2) Overhead Distribution Converted to Underground Distribution.
- (a) Overhead Service. In addition to the equipment on the Customer's side of the metering equipment, the service drop wire holder or bracket, the weatherhead and either the service mast and conduit with entrance wires or the service entrance cable with watertight connection to the meter socket are the property of the Customer.
 - (b) Underground Service. Underground Service Area. In addition to the equipment on the Customer's side of the metering equipment, the Customer shall own secondary wire and terminators if wire is larger than a single 250 kcmil aluminum triplex cable as described in Section 806.

(3) Underground Distribution.

- (a) Overhead Service. In an underground distribution area, overhead services are not allowed.
- (b) Underground Service. In addition to the equipment on the Customer's side of the metering equipment, the Customer shall own secondary wire and terminators if wire is larger than a single 250 kcmil aluminum triplex cable.

204.3 Owner Responsibility. The Customer and MPS are responsible for the installation, maintenance, repair, and replacement of the electric service equipment for which each own.

205 Easements

Whenever any MPS-owned underground and/or overhead material and equipment are located on or above the Customer's property, the Customer shall grant an easement to MPS to the extent which MPS deems necessary. All utility easements by MPS are to be granted by the Customer at no cost to MPS. This does not include secondary service drops or service laterals. Please refer to Section 901.4 for information on service drops and service laterals.

206 Inspection of Customer's Facilities

206.1 Installation Standard. As a minimum, wiring and electrical equipment of the Customer shall be installed in accordance with the latest edition of the National Electrical Code.

206.2 State Electrical Inspector. Wiring installations, including temporary installations, must be inspected and approved by an authorized electrical inspector of the State of Minnesota. MPS will not make connection until authorized by the State inspector or until the master electrician who installed or supervised the installation agrees in writing, that is, an affidavit, to be responsible for said wiring until such time that it can be inspected and approved by the State inspector.

207 Service Connection, Disconnection, and Reconnection

207.1 Service Connection. After the Customer's installation has been inspected and approved by the proper authority, a meter will be installed by MPS and electric service made available provided that all applications, agreements, and deposits have been submitted by the Customer and approved by MPS. Written affidavits and requests must be received by MPS by 24 hours preceding the date that connection is desired. Weekends and holidays are excluded and affidavits and requests will not be received at those times.

207.2 Disconnection or Reconnection. Customer requests for disconnection or reconnection of existing services must be received by MPS at least 24 hours in advance of the requested time of disconnection or reconnection. Requests will not be accepted on weekends and holidays. MPS may deviate from this process if a hazardous situation arises, for example, a fire.

207.3 MPS Employees Only. For the mutual protection of the Customer and MPS, only authorized employees of MPS or approved MPS contractor (under special circumstances) are permitted to set and remove meters or to make and energize or break and de-energize the connection between MPS' service drop or secondary terminals and the Customer's service entrance conductors or secondary service laterals.

208 Liability

MPS does not engage in the practice of doing interior wiring on the Customer's premises, except for the installation and maintenance of MPS' own property, and, therefore, is not responsible for service beyond the point of delivery. MPS shall not be liable for damage to any Customer or to any third party resulting

from the use of the service or from the presence of MPS appliances or equipment on the Customer's premises. The Customer is solely responsible for any accidents, fires, or failures resulting from the condition and use of the Customer's wiring, installation, or equipment.

209 Service Interruption

MPS reserves the right to interrupt service at any time. Interruptions for maintenance and system improvements will be prearranged and advance notice will be given to the Customer whenever practical.

210 Unauthorized Use of Electricity

210.1 MPS Mission. MPS is a public utility engaged primarily in the business of supplying electric service to electrical consumers. Electric service is furnished for the use of the Customer only, and the Customer shall not resell nor permit other persons to use it.

210.2 Submetering Is Illegal. Submetering for resale of electricity is an unauthorized use of electrical service. The Customer shall not submeter any portion of electrical service in any manner for resale.

211 Pole Attachments

Any attachment, especially radio or television antenna systems, to MPS poles is strictly prohibited. Upon discovery by MPS, such attachments will be removed immediately.

212 Access

MPS and its Contractors shall have right of access to the Customer's premises at all reasonable times for the purpose of installing, reading, inspecting, maintaining, or removing any of its meters, devices, or other equipment for which is used in connection with the furnishing of the Customer's electric service.

213 Customer Responsibility

Failure of the Customer to notify MPS in a timely manner of any planned alteration to electric service facilities, of any increase to the electrical load, or failure of the Customer to comply with published MPS rules, regulations, and Rate Schedule may result in delayed connections, interruption of service, or damage to equipment for which MPS disclaims all responsibility. MPS may deviate from this process if a hazardous situation arises, for example, a fire.

214 Revisions of Requirements

All requirements stated or implied herein are subject to change at any time without prior notice. All revisions can be obtained from MPS upon request.

215 Damages to MPS Equipment

MPS property damaged by a customer or others through physical damage, electrical damage, chemical attacks, or cyberattacks, MPS will bill all costs of damage and the cost to repair damage to MPS' equipment or MPS' property to the customer or the other responsible party. MPS may deviate from this process if damage is due to a hazardous situation, for example, a fire.

SECTION 300

RATES, DEPOSITS, AND CONNECTION CHARGES

301 Rate Schedule Classifications

Electric service is supplied to Customers under various rate schedule classifications as determined by the type of service, the amount of electric power supplied, and the purpose for which the electric service is to be used. Copies of the current MPS Rate Schedule are available at the MPS Business Office.

302 Payment for Service

MPS will, insofar as possible, read all meters every month and bill the Customer for service used during the period. Payment of the bill is due on the date noted on the bill. If for some reason the meter cannot be read during a billing period or the reading seems erroneous, an estimate will be made for that billing period. Any adjustments to the estimate will be made during the following billing period. Adjustments to bills resulting from inaccuracies in the meters will be handled in the manner described in Paragraph 610 Meter Testing. For a more extensive explanation of corrections due to billing errors, please refer to the Policy on Billing for Overcharges and Undercharges.

303 Minimum Bill

A minimum monthly bill is charged to each Customer receiving electric service. The amount of this monthly bill varies with the type of electric service which the Customer receives. The minimum bill for each type of service is listed in the MPS Rate Schedule.

304 Service Extension Costs

304.1 New Subdivision Infrastructure Costs. The costs incurred by MPS to provide electric facilities in new subdivisions will not be charged to the owner(s) of that development unless the anticipated revenue over a reasonable time period does not cover the cost to extend the service. If a revenue shortfall is anticipated, the owner(s) shall pay the difference between MPS' costs and the anticipated revenue.

304.2 New Subdivision Electric Buyout Costs. When the City extends its corporate boundaries through annexation or consolidation to an area that has existing electric service from another electric utility and the Commission elects to provide electric service to those newly annexed customers. MPS may negotiate with the existing electric utility for the purchase of electric facilities and customers. The negotiated purchase price may include facilities, lost revenues, and re-integration costs, and are recovered from customer's base on the following:

Electric Service Extension Surcharge – all customers are required to pay an electric service extension surcharge for facilities lost revenues and re-integration costs paid to the existing utility by MPS:

- (1) If the MPS rate for a similar-classed customer is less than the rate charged by the previous electrical supplier, the customer will pay approximately one-half (1/2) the difference in rates to reimburse MPS for the lost revenue and reintegration costs. The customer will pay this fee as adjusted from time to time pursuant to Section 304.2.3 until such time that the facilities lost revenue and reintegration costs are reimbursed in full.
- (2) If the MPS rate for a similar-classed customer is greater than the rate charged by the previous electrical supplier, MPS will not require the customer to reimburse MPS for the lost revenue and reintegration costs until 304.2(1) is viable.

- (3) The Electric Service Extension Surcharge will be adjusted from time to time by the Commission as rates of MPS and the previous electric supplier fluctuate.

305 Service Disconnection and Reconnection

305.1 Service May Be Disconnected with Notice for:

- (1) Non-payment of a delinquent account.
- (2) Failure to pay a deposit due to a previous uncollectible balance.
- (3) Violation of MPS' Electric Service Rules and Regulations or MPS' Water Service Rules and Regulations.
- (4) Failure to allow MPS access to MPS' equipment located on the Customer's premises for inspection, meter reading, maintenance, or replacement of equipment.
- (5) Breach of service contract.
- (6) Failure to furnish those things necessary to obtain service.
- (7) Failure to repair damaged service mast or service entrance equipment.
- (8) When necessary for MPS to comply with an order or request from a government authority having jurisdiction.

305.2 Service May Be Disconnected without Notice for:

- (1) Unauthorized diversion of utility service.
- (2) Unauthorized use of, or tampering with, MPS' service equipment.
- (3) The need to remedy a condition hazardous to the Customer, to other Customers of MPS, to MPS' equipment, to MPS employee(s), or to the public.

305.3 Reconnection Fee. In the event that service has been disconnected for a valid cause, the Customer will be required to pay a reconnection fee.

306 Service Deposits

Refer to MPS' Policy on Deposits.

307 Collection of Past Due Accounts

Refer to MPS' Policy on Collection of Past Due Accounts.

308 Charges for Line Extensions

When a Customer requires a line extension, MPS will extend its services within its authorized service boundaries in accordance with the requirements for overhead and underground extensions only when the anticipated revenue from the sale of additional service, which will result from the extension, is sufficient to justify the expenditure. When the expenditure is not so justified, the extension will be made only if the Customer pre-pays MPS the portion of the capital expenditure not justified by the anticipated annual revenue.

SECTION 400

STANDARD SERVICES

401 General Characteristics

This section describes the types of services offered to Customers under MPS' Rate Schedule. Electric service supplied by MPS is alternating current having a nominal frequency of 60 Hertz (cycles per second).

402 Availability of Service

Although the types of service listed below are generally available throughout the area served by MPS, service of the type requested by a Customer may not be available at the location where such service is requested and, in certain cases, may be available only through special contractual arrangements and at the expense of the Customer. **Each Customer will generally be allowed only one type of service and one point of connection for each location.**

403 Secondary Service Voltages

The following types of secondary service are generally available to Customers served under MPS' Rate Schedule:

403.1 Single-Phase Service. 120/240 Volt, 3-Wire, Grounded Neutral. Single-phase service is generally available where the total load is less than 100kVA.

403.2 Three-Phase Service. Under 3,000kVA capacity.

- (1) 208Y/120 Volt, 4-Wire, Grounded Neutral. Generally available where the total load is 75kVA or greater for underground service, or 50kVA or greater for overhead service.
- (2) 240/120 Volt, Delta, 4-Wire, Grounded Neutral. Generally available where the total load is 75kVA or greater for underground service, or 50kVA or greater for overhead service.
- (3) 240 Volt and 480 Volt, Delta, 3-Wire. Not generally available.
- (4) 480Y/277 Volt, 4-Wire, Grounded Neutral. Generally available where the total load is 150kVA or greater.

404 Primary Service Voltages

Three-Phase, 12470Y/7200 Volt, 4-Wire Grounded Neutral Service. Available only by special request. Please consult with MPS Electric Division staff.

405 Transmission Service Voltages

Transmission service voltages are available only by special request. Please consult with MPS Electric Division staff.

SECTION 500

SPECIAL SERVICES

501 Temporary Service

501.1 Availability. Temporary service is intended to be supplied at secondary voltages only to Customers for use during the construction of permanent facilities and before the permanent service can be installed.

501.2 Requirements. The address of the location to be supplied with temporary service must be permanently displayed at the location and easily readable from the street before MPS will install the temporary service. All overhead and underground temporary services will be metered and billed under the MPS Rate Schedule. MPS will furnish only the service drop or lateral, meter, and metering transformers.

501.3 Customer Equipment. The Customer shall provide an approved meter socket with the necessary raceway and a suitable rigid support for attachment of the metering equipment and service drop or lateral. On large, three-phase temporary services, if required, the Customer shall also provide a suitable enclosure for installation of MPS' instrument transformers.

501.4 Charges for Temporary Service. A nominal flat fee, payable in advance, will be assessed for the first single-phase temporary service of 200 amperes or less installed at the Customer's premises. The location of the temporary service will be designated by representatives of MPS. The Customer will be required to pay MPS for the actual cost to install and remove any additional single-phase temporary service of 200 amperes or less, any single-phase temporary service larger than 200 amperes, any three-phase temporary service, any temporary service located for the convenience of the Customer, and any other special facilities requested by the Customer. Temporary services which require a significant expenditure of money by MPS will be installed only after the Customer has made a deposit based on the estimated cost of construction. Such deposit will be applied as a credit against the actual costs billed for installation and removal of the temporary service facilities. Information regarding the charges for temporary service can be obtained from a Customer Accounts Specialist, who will consult with MPS' engineers.

502 Services for Unusual Load Characteristics

The operation of Customer equipment having a relatively high load of short or intermittent duration, or equipment that generates severe harmonics, such as welders, variable speed drives, electronic devices, compressor motors, elevators, and X-ray equipment, may cause serious fluctuations of voltage and interfere with the service being provided by MPS to other Customers. If such a load is anticipated, the Customer must consult with MPS and agree to install such protective devices as may be required so as not to cause damage to any of MPS' equipment or in any way inhibit service to other Customers. In addition, special compensation may be required by MPS from the Customer in those cases where it is necessary for MPS to install special or larger facilities than would normally be required to provide satisfactory service.

503 Redundant Facilities

MPS will normally provide one set of facilities, such as a set of primary cables and a transformer, to one point of service for each Customer. If a Customer requires redundant facilities, that is, more than one set of facilities to the same point of service, then MPS must be advised as soon as possible so the feasibility of such service can be determined. If MPS determines that redundant facilities can and will be provided, the Customer will normally be required to reimburse MPS for the time and materials necessary for the additional facilities. An agreement between the Customer and MPS may also be required.

Last updated: 02/17/2026

v7.0

504 Relocation or Protection of MPS Facilities

Because MPS encourages economic development within the city of Moorhead, MPS will contribute to the costs of relocation and protecting MPS' equipment to the extent the change benefits MPS. The most likely benefit would be an increase in electric sales revenues. MPS will offset the increase in electric revenues against the project costs. Any remaining costs shall be shared equally between the Customer and MPS. If there is no benefit to MPS, MPS will not share in the project costs.

MPS shall have the right to require the Customer to pay a deposit before commencing work on a proposed project.

The Customer shall not be required to pay for changes that are authorized by a city, county, or state public improvement mandate. Costs for relocations due to City of Moorhead projects shall be paid by the City of Moorhead, less any amount attributed to electric system improvements.

505 Security Lighting

Security lighting is available under its own rate schedule classification for those Customers requesting it. Security lighting is not generally available in underground areas.

506 Underground Locations

MPS owns and operates many miles of underground high-voltage electric lines. In order to protect the public from serious or fatal injury and to minimize disruptions of service to its Customers, MPS will, at no charge, locate and mark the approximate location of its underground lines. Customers, contractors, and others planning to undertake any type of excavation within the MPS service area, must contact Gopher State One-Call by telephone at 800.252.1166 to request a location. All requests for locations must be made at least 48 hours before the anticipated time of digging or construction, weekends and holidays excluded, except in emergencies.

CAUTION: Digging within two feet of cable shall be by hand. Any contact with an underground line during digging or construction must be reported immediately, day or night, to MPS at 218.477.8080.

507 Dual-Fuel Program

507.1 Availability. MPS' dual-fuel rate is available to all residential and commercial dual-fuel Customers who comply with these regulations.

507.2 Application for Service. Residential and commercial Customers applying for the dual-fuel program must fill out a dual-fuel application and sign the dual-fuel agreement.

507.3 Heating System. The primary heating system for the home or business shall be permanently-connected electric heat. The primary heating system must provide 100 percent of the heating needs for the home or business during the off-peak hours.

The secondary heating system must utilize thermal storage or be fueled by natural gas, fuel oil, or propane. The secondary heating system must be thermostatically-controlled and capable of providing the Customer's total heating requirements during MPS control periods. The Customer must submit a guaranty from their heating contractor stating that the secondary heating system is capable of meeting the home's entire heating needs.

507.4 Heat Pumps. Electric heat pumps and their supplemental electric heat components qualify as a primary heating source for the dual-fuel program if the unit provides 100 percent of the heating needs of the home or business during off-peak hours. A qualified secondary heating system must be present if electric heat pumps are used.

Residential Customers with heat pumps are required to also control the cooling component (air conditioning) of the heat pump. MPS will compensate the residential Customers using heat pumps for air conditioning with the dual-fuel rate.

Commercial Customers with heat pumps will not be controlled or receive the dual-fuel rate for the air conditioning component of the heat pump. Instead, MPS will compensate commercial Customers on the Small General Service rate during the summer season as defined by MPS' Rate Schedule.

507.5 Radiant Floor Heat. Electric radiant floor heating, such as an electric boiler hydronic system or an electric cable system, qualifies as a primary heating source for the dual-fuel program if the unit provides four hours of the heating needs of the home or business during a load management event.

Radiant floor heat storage may also be used as a qualified secondary heating system; however, the heating contractor must submit a guaranty to MPS stating the radiant floor storage is capable of meeting the home's entire heating needs.

507.6 Thermostat. The primary and secondary heating systems must be on a common thermostat. This results in temperature stability when MPS requires the secondary system to operate.

507.7 Customer Bypass Switch. The control scheme wiring installed by the Customer's electrician must include a test bypass switch. This switch will enable the Customer to manually switch off the primary electric heating and turn on the secondary heating for maintenance and testing.

507.8 Metering Requirements. Qualified Customers are required to have an additional meter to measure the dual-fuel electricity. MPS does not allow sub-metering or subtractive metering. The regular service meter, dual-fuel meter, and dual-fuel control unit must be mounted on the outside of the Customer's home or business.

507.9 Equipment Furnished by MPS. The dual-fuel meter, in-line fuses, and dual-fuel control unit will be furnished to the Customer. MPS will own and operate these devices.

507.10 Equipment Furnished by the Customer. Customers shall provide all other equipment not furnished by MPS. This includes a primary and secondary heating system and all electrical wiring necessary to permit switching of controlled electric loads.

507.11 Equipment Installation. All equipment installed by the Customer must conform to MPS' rules and regulations, the State of Minnesota Electrical Code, and the National Electrical Code. All equipment shall be installed at the Customer's expense.

507.12 Dual-Fuel Control Unit. The dual-fuel control unit provided by MPS shall be mounted in an upright position adjacent to the dual-fuel meter with the wiring connection made through approved conduit and "T" or bell box. The dual-fuel control unit shall be easily accessible for maintenance and testing.

507.13 Control Wiring. All 120-volt/240-volt control transformers for heating and cooling must be fed from the same circuit as the fan in a forced air system, from the same circuit as the pump in a hot water system, from the same circuit as the living room heat circuit of a baseboard system. Wiring to the dual-fuel control unit must have a minimum insulation of 600-volt rating. All control wire splices shall be placed in an approved demarcation box and wired in accordance with the NEC.

507.14 Affidavit. Customers applying for a dual-fuel electric service must file an affidavit with MPS. This affidavit will require inspection by a State electrical inspector.

507.15 Inspection by MPS. MPS will inspect the installed equipment to assure that it conforms to regulations. MPS will also periodically inspect the operation of the dual-fuel control unit and heating system.

507.16 Electric Storage Water Heaters. Qualified residential dual-fuel Customers may elect to add their electric storage water heater to the dual-fuel rate. MPS offers two options of water heater control:

- 1) **Short-Term Control.** Water heaters will be controlled less than four hours at a time. Customers using this option will receive a monthly billing credit, as provided for in MPS' Rate Schedule. Water heaters using short-term control must be wired to the main service panel and are not eligible for the dual-fuel rate.
- 2) **Long-Term Control.** Water heaters will be controlled up to eight hours at a time. Water heaters using long-term control must be wired to the dual-fuel panel and will receive the dual-fuel rate as approved in the Rate Schedule.

507.17 Central Air Conditioners. Qualified residential dual-fuel Customers may elect to add their single-phase, 240-volt, central air conditioner to the dual-fuel rate. The Customer must provide a system that uses the common dual-fuel relay contact in the dual-fuel control unit. During control periods, the compressor of the air conditioner will be cycled in approximately 15-minute on/off cycles.

507.18 Other Qualifying Loads. Qualified dual-fuel residential Customers may elect to add permanently-wired electric heating units for hot tubs and pool heaters to the dual-fuel rate. Permanently-wired, 240-volt, electric garage heat is also eligible for the dual-fuel rate. Customers should be aware that no secondary heating system is required for these loads and, therefore, the heat will be shut off during MPS control periods.

507.19 Non-Qualifying Loads. Appliances, including washers, dryers, ranges, and saunas, are not eligible for the dual-fuel rate.

507.20 Customer Bypass Switch. The control scheme wiring installed by the Customer shall include a test bypass switch. The switch will enable the Customer to manually switch off the primary electric heating and turn on the secondary heating for the maintenance and testing to secondary heating system for maintenance and testing.

507.21 Maintenance of Equipment. The Customer shall maintain all equipment except the dual-fuel control unit and any meters owned by MPS.

507.22 Tampering. If MPS discovers that any service has been tampered with so as to defeat the intent of these regulations, the Customer will immediately be removed from the dual-fuel rate. All electricity on the dual-fuel meter used between the last inspection and discovery of the tampering will be billed at the highest rate in effect for the Customer class.

507.23 Liability. MPS will be held harmless from any obligation or responsibility concerning the installation or operation of any system connected to the dual-fuel meter. Maintenance of the system is completely the responsibility of the Customer.

507.24 Multiple Dwelling Residences and Commercial Dual Fuel. If a central heating system is used for primary/secondary heat, the complementary primary/secondary heating system must also be a central unit for **all** multiple units. Likewise, if an individual unit has an independently metered primary heating service, the secondary heat must be an individual unit. The dual-fuel program is available to multiple dwellings only if **all** units within are changed to dual fuel.

507.25 Customers Moving into a Home with Dual Fuel. Customers who purchase or move into a home that currently participates in the dual-fuel program will automatically continue to receive the dual-fuel rate, unless the Customer notifies MPS. MPS will inform the Customer of the program rules and regulations.

507.26 Ending Participation in the Program. Customers who no longer wish to participate or are removed from the dual-fuel program must wait one full year from termination to re-apply for the program. MPS will schedule a time to remove the dual-fuel control unit and meter. Customers no longer participating in the program must hire an electrician to move the heating/water heating/air conditioning, permanently-wired electric heating units for hot tubs and pool heaters, and electric garage heat from the dual-fuel panel to the main service panel. Alternately, customers can request to leave meter for dual fuel in place, and pay all applicable costs and rates, if MPS approves.

508 Interruptible Service Program

508.1 Availability. The Interruptible Service Program is available to all commercial, industrial, and government Customers of the General Service Rate class, and a minimum of 100 kW of interruptible electrical load.

508.2 Application for Service. MPS Customers must complete an application and sign an agreement. This agreement ensures that the Customer conforms to all interruptible service rules and regulations.

508.3 Eligible Equipment for Curtailable Loads. The Customer who applies for the program must have at least 100 kW of interruptible electric load per meter location. The selected interruptible load must be permanently connected to the Customer's electric panel. MPS will verify the rated load and usage of selected equipment in determining eligibility for the program.

508.4 Eligible Equipment for Customer Generation. The Customer who applies for the program must have at least 100 kW of Customer generation. Customers must adhere to Section 706 of MPS' Electric Service Rules and Regulations pertaining to Customer-owned generating equipment. MPS will verify the rated generation capacity and load reduction of the equipment in determining eligibility for the program.

508.5 Metering Requirements. Qualified customers depending on the interruptible electric load may require an additional demand meter to measure the interruptible electricity. The interruptible electric load may require an additional service, and must conform to MPS rules and regulations. MPS does not allow sub-metering or subtractive metering.

508.6 Equipment Installation. All equipment installed by the Customer must conform to MPS' rules and regulations, the State of Minnesota Electrical Code, and the National Electrical Code. All equipment shall be installed at the Customer's expense.

508.7 Billing Credit. The Customer shall receive a billing credit according to MPS' Rate Schedule for each month that the interruptible electric load is curtailed during all control periods in that month.

The Customer shall receive the billing credit for a month in which there is no control period if the Customer received the credit for the prior month in which there was a control period. The interruptible electric load may not exceed the billing demand for any given monthly billing period.

508.8 Duration of Load Control. The duration of control period shall be determined by MPS. A control period begins 30 minutes after the Customer receives notification or 30 minutes after MPS attempts notification. The control period ends when MPS gives notification that the interruptible electric load may return to service. The method of notification shall be one telephone call from MPS to the Customer or the Customer's representative.

The annual curtailment periods for the Curtailable Load and Customer Generation Customers shall not exceed 300 hours per calendar year.

508.9 Inspection. The Customer agrees to allow MPS the right to enter the Customer's premises to inspect the installation of the interruptible service and to periodically inspect the operation of the system.

508.10 Verification of Load Control. The Customer agrees to allow MPS to verify that selected equipment is being curtailed through use of metering and inspections at the Customer site.

508.11 Failure to Control Electric Load. MPS reserves the right to remove the Customer from the Interruptible Service program and/or delay a monthly billing credit if the Customer does not adequately curtail the selected interruptible load.

The monthly billing credit will be denied if the Customer fails to adequately curtail the selected interruptible load during the MPS peak electric demand period for the selected month. MPS will review metering information to verify the existence or absence of load control.

If the Customer is denied the monthly billing credit three times in a 12-month period, MPS will remove the Customer from the Interruptible Service program and the Customer will no longer receive the Interruptible Service program billing credit.

508.12 Changes to Operations or Equipment. MPS reserves the right to remove the Customer from the Interruptible Service program and/or deny a monthly billing credit if the Customer makes changes to their operations or equipment identified in the Interruptible Service program application.

508.13 Ending Participation in the Program. Customers who no longer wish to participate or are removed from the Interruptible Service program must wait one full year from termination to reapply for the program.

509 Aggregation of Retail Customer Demand Response

Moorhead Public Service or its authorized designee is the sole entity permitted to bid demand response on behalf of retail customers served by Moorhead Public Service directly into any Commission-approved independent system operator's or regional transmission organization's organized electric markets.

Retail customers served by Moorhead Public Service wishing to bid their demand response into a Commission-approved independent system operator's or regional transmission organization's organized electric markets may do so by participating in the program established by Moorhead Public Service or its authorized designee. Retail customers are not permitted to participate in the demand response program of any other entity without the express prior authorization of Moorhead Public Service.

510 Ancillary Services Provided by Demand Response Resources

Moorhead Public Service or its authorized designee is the sole entity permitted to bid demand response on behalf of retail customers served by Moorhead Public Service directly into any Commission-approved independent system operator's or regional transmission organization's organized markets for energy imbalance, spinning reserves, supplemental reserves, reactive power and voltage control, or regulation and frequency response ancillary services (or its functional equivalent in the Commission-approved independent system operator's or regional transmission organization's tariff).

Retail customers served by Moorhead Public Service wishing to bid their demand response into a Commission-approved independent system operator's or regional transmission organization's organized markets for energy imbalance, spinning reserves, supplemental reserves, reactive power and voltage control, or regulation and frequency response ancillary services (or its functional equivalent in the Commission-approved independent system operator's or regional transmission organization's tariff) may do so by participating in the program established by Moorhead Public Service or its authorized designee. Retail customers are not permitted to participate in the demand response program of any other entity without the express prior authorization of Moorhead Public Service.

SECTION 600

METERS

This section covers the installation of meters and associated equipment, such as current and potential transformers for both overhead and underground services. Further description of MPS' requirements for both overhead and underground services is covered in other sections of this booklet. The requirements contained in this section are for services rated 600 volts or less. When services are required at primary voltage, such as 12470Y/7200 volts, the metering requirements and equipment will be determined on an individual basis.

601 Responsibilities for Providing Metering Equipment

601.1 MPS' Responsibilities. MPS supplies, at its own expense, all meters and such accessories as are required for billing purposes, including watt-hour and var-hour meters, demand meters, totalizers, current and potential transformers, phase-shifting transformers, test switches, and color-coded meter wiring.

601.2 Customer's Responsibilities. It is the Customer's or the Customer's representative's responsibility to secure a meter socket base and a slip conduit section on the riser pipe or meter center for multiple meter installations. Meter sockets for installations requiring instrument transformers may be obtained from MPS. **For the safety of the employees, all meter sockets must be ringless, have a lever bypass, and a minimum rating of 200 amps.** Unless by special permission, with the exception of apartment buildings if the breaker or disconnect is directly below the meter socket, MPS will install only one set of metering equipment under each contract or application for one class of service. Electric Division staff need to be consulted for determination of the type of metering to be employed in each installation.

602 Capacity of Service

A single-phase service shall not supply a load in excess of 400 amps without special permission. Service to single family residences shall be limited to 400 amps single-phase, except by special permission. Three-phase service is not limited as to capacity, except that MPS may require that loads of large demand be supplied by a transmission or primary service to transformers on the Customer's premises.

603 Remote Water Meter Register

When a Customer relocates their electric meter from inside to outside the building, for whatever reason, then the water meter must have an Advance Metering Infrastructure (AMI) meter installed by MPS. If the existing water meter does not have the capability to connect to AMI, then MPS will replace the water meter with an AMI meter at no charge.

604 Location of Meters

Meter locations will be agreed-upon by representatives of the Customer and MPS, subject to final approval by MPS.

604.1 Residential. All new residential services must have the meter located outdoors. In all underground areas, residential meters must be located in front of the first egress window well and within 10 feet of the front of the building, unless that location is not practical as determined by MPS' operations and/or engineering personnel. No new residential services may be located in the rear of the building. Meters must be relocated outdoors whenever the Customer upgrades the electrical service. Old water heater meters must be removed and the meter socket removed when the

Customer makes any changes to the water heater wiring. No other equipment may be wired to the water heater meter.

604.2 Multiple Dwellings. Where more than one meter is installed, as on apartment houses, the meters shall be grouped, either outdoors or indoors, at a point accessible at all times to each Customer and to MPS employees. Refer to Section 605.

604.3 Industrial and Commercial. Meters for industrial and commercial service shall be located outdoors. If this is not possible, meters shall be located at a point accessible at all times to Customers and MPS employees.

604.4 Height Limits. In all cases where the meter is mounted on a permanent structure, the meter shall have a height of not more than 72 inches and not less than 48 inches from final grade to the center of the meter. A typical residential underground metering arrangement is shown in Section 1000, Appendix 2, Exhibit 1.

604.5 Mobile Homes. MPS will individually meter each mobile home located in a mobile home court or addition to a mobile home court. Resale of metered electrical energy by the court owner will not be permitted in these facilities. Individual or grouped meter pedestals shall be provided by the Customer or the Customer's representative. A typical mobile home metering arrangement is shown in Section 1000, Appendix 2, Exhibit 2.

604.6 Meter Clearances. Meters shall be situated such that there is not less than three feet of unobstructed space in front and one foot on either side thereof. Meters shall not be located where they are subject to corrosive fumes, heat, dust, vibration, or physical damage. Outdoor meters shall not be located in carports, under decks or porches whether open or enclosed, in dog kennels, over central air units or natural gas meters, or along walkways or driveways where they might create a hazard to people or be subject to damage by passing objects.

604.7 Access to Meters. Meter locations shall not be hazardous or cause inconvenience to MPS employees when installing, maintaining, or reading the meters.

605 Grouped Meters

In installations requiring more than one meter, the meters shall be grouped and suitably connected such that a meter serves no more than one Customer. The height limits stated in Appendix 2, Exhibit 4, also pertain to grouped meters where practicable. If deemed necessary by the space available, the meters may be stacked in an orderly fashion. Any dwelling with more than one Customer must have an individual meter for each dwelling unit. These meters must be easily accessible to all tenants and to MPS employees. There shall be an approved means of disconnecting each meter, which can be locked to prevent reconnection by anyone other than MPS employees. A typical multiple metering arrangement is shown in Section 1000, Appendix 2, Exhibit 3.

606 Meter Identification

If more than one meter is required for a building or for meters in a mobile home park, each meter socket shall be **identified and permanently designated** in a suitable manner indicating the particular Customer served. The marking shall be on **both the inside and outside** of the socket. Each circuit shall be carefully traced and rechecked by the contractor to ensure against errors in wiring, whereby one Customer might obtain service through the meter serving another Customer. This is especially important when the wiring is concealed.

607 Meter Mounting

607.1 Outdoor Meters. Outdoor meters and meter-mounting devices shall be mounted securely on permanent structures such as houses, garages, and other buildings. Where outdoor meters are installed on surfaces which prevent installation of the meter-mounting device in an exact vertical plane, a meter board must be installed or the surface modified in such a manner that the meter-mounting device can be installed vertically.

607.2 Indoor Meters. Indoor meters, where permitted, shall be mounted in accordance with the preceding requirements of this section and shall be located as close as possible to the point where service enters the building. Indoor metering equipment shall be mounted securely in a vertical plane on permanent structures in a location free from moisture, high temperature, vibration, dust, or dirt.

608 Meter Connections

The Customer shall provide the necessary wiring for the meter set with the wiring arranged so that the line or supply side can be connected to the top terminals of the socket and the load side to the bottom terminals. All conductors shall extend into the meter socket a minimum distance equal to the length of the socket trough. All neutral conductors must be insulated. Where the service is three-phase, 4-wire delta, the Customer's phase wires on the load side of the meter shall be permanently identified as recommended in the National Electrical Code. The conductor serving power load only shall be permanently identified as recommended in the National Electrical Code. The conductor serving power load only shall be permanently identified or have a distinctive orange covering, and shall be connected to the top, right-hand terminal of the meter socket. For underground services, the line side neutral wire is to be identified with a yellow covering or stripe. There shall be sufficient slack left in the underground cables to make up for any ground shifting due to settling or extreme cold.

609 Wiring Restrictions on Meters and Metering Sets

No part of the metering set may be used as a demarcation box for the Customer's wiring. See appropriate section of the NEC.

610 Meter Testing

610.1 Request for Meter Testing. Any Customer, who believes that a meter is failing to properly register the use of electricity, may request a meter check by contacting a Customer Accounts Specialist. MPS will test the meter using standard calibration equipment and generally accepted test procedures within a reasonable period of time at the Customer's expense, as determined by MPS, except when the meter is found to be more than 2 percent in error.

610.2 Bill Recalculation. Whenever a watt-hour meter is found upon test to have an average error of more than 2 percent from 100 percent or a demand meter more than 2 percent from 100 percent, a recalculation of bills for service will be made on the basis that the meter should be 100 percent accurate with respect to a working test standard.

610.3 Duration of Inaccurate Measurement. If the period of inaccuracy cannot be determined, it will be assumed that the metering equipment has become inaccurate at a uniform rate since it was last tested or installed unless there is a valid reason to use another method. Recalculation will be made based upon the best available information.

610.4 Failure of Equipment. When the average error cannot be determined by testing due to complete failure of all or part of the metering equipment, then an estimate of the quantity of energy consumed based on available data will be used to determine the adjusted bills.

611 Meter Seals and Tampering

All connections to MPS service equipment shall be made by MPS employees only. **Unauthorized connections to or tampering with any MPS meter, associated equipment or meter seals, or indications or evidence thereof subjects the Customer to immediate discontinuance of service, prosecution under the laws of Minnesota, adjustment of prior bills for service rendered, and reimbursement to MPS for all extra expenses incurred on the account.** In addition, when the unauthorized connections or tampering involve an inside meter, the Customer shall, at the Customer's own expense, relocate all metering facilities outside the building.

612 Instrument Transformer Installation

When the ampacity of the service entrance conductors is greater than the ampacity of the meter socket base, it will be necessary for MPS to use current transformers in the metering installation. When the voltage of the service is over 480 volts, it is necessary to use voltage transformers. The instrument transformers shall be installed on the line side of the Customer's service entrance disconnect switch. The Customer shall not install any additional disconnect switches or demarcation boxes on the line side of the instrument transformer location. MPS will provide the instrument transformers to the Customer for installation in the current transformer cabinet or transition cabinet. MPS uses only bar type current transformers. MPS also provides the meter socket for instrument transformer metering installations.

612.1 Underground Service from Pad-Mounted Transformers. Where service is served from a 75kVA through a 3000kVA pad-mounted transformer, the Customer must install a separately mounted metering current transformer box and a metering potential transformer box when potential transformers are required.

612.2 Metering Conduit. The Customer must furnish and install a 1-inch metering conduit from the instrument transformer location to a meter location approved by MPS. The conduit shall not contain more than four 90° bends. When the conduit is longer than 50 feet, a pull wire shall be installed in the conduit. Conduit runs shall not exceed 125 feet except by special permission. MPS shall install the meter wiring between the instrument transformer and the meter.

612.3 Current Transformer Cabinets. Metering current transformer boxes shall be furnished and installed by the Customer. The service entrance phase conductors installed in a metering current transformer box may be made of up to four identical wires in parallel per phase for conductor sizes between 1/0 and 500 kcmil. Each pair of paralleled phase conductors shall be of the same color or shall be taped together or otherwise marked for easy identification.

612.4 Transition Cabinets. When the total cross-sectional area of the service entrance conductors is greater than 2,000 kcmil (4-500 kcmil) per phase, a transition cabinet immediately adjacent to the transformer must be used. When more than four Customers are served from a 500kVA or larger transformer, a transition cabinet must be used. The details of a transition cabinet installation must be approved by Electric Division staff before construction.

612.5 Overhead Service. Where service is provided by overhead service drops, current and potential transformers will be mounted in appropriate metering transformer boxes on the building.

612.6 Overhead Service Entrance Conductors to Multiple Customers. When more than one Customer is served from an overhead service drop, outdoor mounted current and potential transformers will not be provided. Each Customer requiring metering transformers must install appropriate metering transformer boxes as specified elsewhere in this section.

SECTION 700

CUSTOMER UTILIZATION EQUIPMENT

The Customer's service entrance and utilization equipment shall be installed in accordance with all local, state, and National Electrical Code requirements. It is the intent of this section to provide the Customer with recommendations concerning factors that can affect both MPS and the Customer in the selection, installation, maintenance, and operation of the Customer's utilization equipment. If concerns arise that are not covered in this section, an MPS Electric Division staff member should be contacted.

701 Motor Protection Devices

The MPS power system is designed to provide high speed reclosing of its protective devices following power interruptions resulting from lightning or other causes. In most instances, these power interruptions will be of short duration, less than one second. MPS recommends that under-voltage motor protection be equipped with time delay devices to permit motors to ride through these short duration interruptions. Please note that large motors should be analyzed for their shaft torque limits. It is recommended that over-current protective devices be provided in each phase to afford some motor-running protection of three-phase, 3-wire motors against "single-phasing."

702 Motor Starting Currents

Generally, all motors require a starting current substantially greater than their normal running current. Where starting currents are excessive, an abnormal drop in supply voltage will result. In order to minimize the unfavorable effects of such voltage drops, it is essential that the Customer's motors do not exceed the following allowable starting characteristics.

EQUIPMENT RATED AT:	TOTAL LOCKED ROTOR CURRENT NOT TO EXCEED:
120 volts, single-phase	50 amp
240 volts, single-phase	
2 hp or less	60 amp
2 hp thru 5 hp	60 amp plus 20 amp per hp in excess of 2 hp
240 volts, three-phase	
2 hp or less	50 amp
2 hp thru 25 hp	50 amp plus 14 amp per hp in excess of 2 hp

Note: Customers planning to install any motor larger than 5 hp single phase or 25 hp three-phase must contact MPS for review and approval.

703 Power Factor

In order to improve the efficiency of MPS' distribution system, the Customer's utilization equipment shall maintain an average power factor as close to unity as possible. Some of the classifications in MPS' Rate Schedule include a demand charge and a potential penalty that may be imposed for a power factor that is less than 95 percent. Details of the method for billing for such Customers can be obtained from MPS. For new services, it is suggested that the Customer's utilization equipment be designed for operation at high power factor or with capacitors that are switched on and off with the equipment.

704 Fault Currents

The Customer's service equipment and other devices shall be adequate to withstand and interrupt the maximum available fault current. For single family residences with service equipment rated 200 amperes maximum and 120/240 volts, single-phase, equipment shall have a minimum interrupting rating of 10,000 amperes symmetrical and other equipment shall be braced to withstand that minimum value. For other than single family residences, MPS' Electric Division staff shall be contacted for information to determine maximum existing and future anticipated fault currents.

705 Wiring Adequacy

The National Electrical Code specifies the adequacy of wiring with respect to safety but such installations may not be efficient, convenient, or adequate for good service or future expansion of electrical use. In many instances, the installation of wiring capacity greater than minimum code requirements is strongly recommended.

706 Customer-Owned Generating Equipment

Unless authorized by written agreement, electric generating equipment installed by the Customer shall not be interconnected or operated in parallel with MPS' system. The Customer shall own, install, operate, and maintain electrical interlocking equipment which will prevent parallel operation and such equipment shall be approved by MPS prior to installation.

707 Energy Conservation

MPS encourages the prudent and efficient use of the electric power and energy for which it provides. Customers wanting special information or other assistance regarding the efficient end use of electricity should contact MPS for more information at (218) 477.8000.

708 Cogeneration/Distribution Generation Rules

Cogeneration rules are on MPS' website at [MN Distributed Generation Workbook for MPS](#).

709 Harmonics and Voltage Distortion

The Customer shall not allow harmonics (voltage or current) distortion to exceed a level that will adversely affect the reliable distribution of electric energy of MPS, or any of MPS' system or its devices. Harmonic distortion will be determined at the point of service. The latest revision of IEEE Standard 519 will be used as a guide for allowable limits of harmonic distortion.

If harmonic distortion exceeds acceptable levels, the member shall mitigate the problem immediately by use of filters, reactors, or other recommendations of the manufacture of the harmonic producing equipment.

MPS will help the customer measure levels of harmonic distortion and determine a solution.

709.1 Voltage Flicker. This section provides guidelines for allowable voltage flicker and voltage sag on the MPS' system during large block loading situations. These guidelines can also apply to generator block loading calculations and evaluation of voltage disturbances due to other load issues. The person or customer causing objectionable voltage flicker is responsible for correcting the problem that is created. Table 1 (shown below) documents reasonable levels which voltage flicker should not be objectionable. Reasonable limits for other starting frequencies can be interpolated from the table or derived from the most current version of the IEEE Standard 141-1993 flicker curve graph.

The limits established for the three columns are based on the perception of flicker at the different frequencies of occurrence from the most current version of the IEEE Standard 141-1993 and the relative number of members that would be affected. Flicker imposed on MPS' primary lines is limited to just above the borderline of the visibility since it can affect other customers on the same primary line.

Table 1. Voltage Flicker Limits:

Loading Frequency*	On MPS Primary Lines	At Customer's point of connection to MPS facilities	At Customer's Utilization Location*
1 starts per Hour or greater	3.0%	4.0%	6.0%
5 starts per hour or greater	1.7%	2.5%	3.5%
20 starts per hour or greater	1.0%	1.5%	2.5%

*This level is only shown for reference and is not an MPS limit.

The Flicker at the customer's connection to MPS' facilities is pertinent when other customers are served from the same transformer. The other customers will be subjected to the flicker levels seen at the common connection point. Its location is typically at the secondary terminal of the transformer or secondary pedestal. The limits for this situation are defined as midway between visibility and the borderline of irritation.

The last column shows recommended flicker limits for other utilization location of the MPS electrical system. A good electrical design will hold voltage flicker at the utilization points to the levels shown or better. The limits listed are just below the borderline or irritation. It is the customer's choice what the level of voltage flicker they will impose upon their facilities. Voltage sag limitations are normally less of a constraint than voltage flicker. MPS uses ITI Voltage Tolerance Envelope (CBEMA Curve) as a guideline to evaluate effects of voltage sags. Equipment should tolerate voltage sags to 80% of the nominal service voltage for up to ten seconds and to 90% continuously according to the voltage tolerance limits.

SECTION 800

OVERHEAD SECONDARY SERVICE

MPS will supply overhead secondary service, 600 volts or less, at the voltages and under the conditions specified in other sections of MPS' Electric Services Rules and Regulations. The service entrance location will be specified by MPS. This section includes information on distribution transformer size, overhead service drop, and connections to the Customer's premises or equipment. Metering and Customer equipment requirements are covered in other sections of these rules and regulations. The requirements of this section apply to all residential, commercial, and industrial Customers.

801 Maximum Transformer Size

801.1 Transformer Size. The maximum overhead transformer size installed by MPS will be 100kVA: either one 100kVA transformer for a single-phase application or two or three 100kVA transformers for multi-phase applications. If a larger transformer size is required for a particular application, it shall be a pad-mounted type.

801.2 Secondary Services. One or more secondary services may be supplied from a transformer. The number of services from a transformer shall be determined by MPS depending upon the application.

802 Service Drop Conductors

802.1 New Services. The service drop for new services will be a twisted wire triplex (three wires) or quadruplex (four wires) configuration from the distribution system to the point of attachment on the Customer's premises.

802.2 Existing Services. Existing services may be either a twisted wire or open wire configuration. If necessary, MPS may change a service from an open wire to a twisted wire configuration.

803 Clearances

803.1 Minimum Clearance. The service drop must be so located that the minimum clearance as specified in the latest editions of the National Electrical Code and the National Electrical Safety Code are maintained. An illustration of the clearances required is shown in Section 1000, Appendix 2, Exhibit 4.

803.2 Installation Restrictions. Service drop conductors shall not be installed above a swimming pool or surrounding area unless the National Electrical Safety Code requirements are met.

804 Point of Attachment

A solid point of attachment for supporting the service drop on the building shall be provided by the Customer at a point which will comply with previously stated clearances. Where the required heights and clearances cannot be maintained by a point of attachment on the building, the Customer shall provide a service mast, which is of a permanent nature and of sufficient strength to support the service drop at the required minimum clearance. Typical building attachment and service mast installations are shown in Section 1000, Appendix 2, Exhibits 5 and 6, respectively. In such an installation, 2-inch or larger galvanized iron conduit or 3-inch or larger rigid conduit shall be used. MPS reserves the right to decline to connect its service drop to an extension support which, in its judgment, constitutes a hazard to life or property.

805 Service Entrance

The Customer's service entrance wiring shall terminate at a point so located that the service drop from the supply lines will not interfere with windows, doors, awnings, drainpipes, or other parts of the building or other obstructions and so that only one bracket is required.

806 Electric Distribution Converted from Overhead Distribution to Underground Distribution

When MPS converts overhead distribution to underground, MPS will design these conversion projects to maintain existing overhead services, but also leave customers the option to convert their existing overhead service to an underground service. This design should consist of MPS installing a demarcation point as stated in Section 901.3. MPS will continue to own the overhead service wire, described in section 204.1(2)(a), that was installed to the demarcation point as part of the overhead to underground conversion. When a customer elects to convert their overhead service to an underground service, MPS may provide up to 250 kcmil aluminum Type USE cable. Upon the completion of the conversion from overhead service to underground service, MPS will take over ownership of the underground service as stated in Section 204.1(2)(b).

SECTION 900

UNDERGROUND SERVICE

901 Undergrounding in New Residential Developments

901.1 Availability. New developments will be considered for underground installation of all distribution facilities.

901.2 Requirements. In all areas considered for underground facilities, the developer must agree to:

- (1) Furnish MPS with a recorded plat of the area for which service is requested.
- (2) Establish grades along the underground system route which shall be within 12 inches of finished grade.
- (3) Clear the established cable route of all obstructions such as trees, fences, foundations, dirt piles, and other rubbish.
- (4) Refrain from installation of curb, blacktop, sidewalks, etc., that will increase installation cost until after electric lines are installed.
- (5) Provide property and grade stakes as required by MPS.
- (6) Not plan construction after November 1 or before May 1, unless an extra winter construction charge is paid.
- (7) Provide an easement for installation of MPS facilities on private property if it is agreed to be mutually beneficial.
- (8) Pay an amount to be determined by MPS for capital costs that are unrecoverable from the expected loads being added to the system. This fee must be paid to MPS prior to the initiation of construction of the facilities.

901.3 Point of Demarcation. The point of demarcation is the physical dividing line between MPS-owned equipment and customer-owned equipment. MPS will own, operate, and maintain all underground laterals on services less than 400 amps on the line side, up to the line side of the metering equipment and/or current transformer (CT) cabinet. The ownership of equipment is described in more detail in Section 204.

901.4 Easements. MPS primary and/or secondary services and/or service laterals will normally be installed within front or rear lot line utility easements provided by the Customer as a part of the recorded property plat. All utility easements requested by MPS are to be granted by the Customer at no cost to MPS.

902 Residential Undergrounding in Overhead Areas

Customers residing in residential zones served by overhead lines may install underground electric service. The Customer shall install, own, operate, and maintain the facilities specified in Section 901.3, Demarcation Point, and Section 204.2(2)(b), Underground Service. MPS may provide up to 250 kcmil aluminum Type USE cable.

903 Underground Service to Commercial and Industrial Customers

903.1 Availability. MPS encourages the underground installation of primary and secondary distribution service laterals to new commercial and industrial structures.

903.2 Demarcation Point. MPS will designate a demarcation point for the connection of the Customer's secondary underground service lateral. The demarcation point will normally be the secondary terminals of a pad-mounted transformer placed at a mutually agreeable location on the Customer's property, as close as practicable to the metering point. The secondary connections will be furnished by the Customer.

903.3 MPS Ownership. MPS will install, own, operate, and maintain the primary underground cable and the distribution transformer.

903.4 Primary Cable Installation. The primary cable will be installed from the MPS main distribution system on or adjacent to the Customer's property to the distribution transformer.

903.5 Transformer Pads. MPS may provide transformer fiberglass pads. If the Customer wishes to have a concrete transformer pad to incorporate into the landscaping, the Customer shall furnish and install a transformer pad to MPS' specifications. If the transformer is located in an area where it may be subject to physical damage, for example from vehicular traffic, the Customer shall furnish and install an approved means of protection before installation of the transformer.

903.6 Responsibilities: Over 400 Amperes. For all services larger than 400 amperes, the Customer shall install, own, and maintain all secondary cables and conduits from the transformer to the building service entrance. MPS' Electric Division staff must approve the design of all secondary bus duct and cable bus designs requiring special connections at the transformer. The installation will be inspected by MPS and the secondary connections to the transformer will be made by the Customer. It is the Customer's responsibility to coordinate with and provide the necessary information to MPS' Electric Division staff to assure that adequate connections are made at the secondary terminals of the transformer.

903.7 Meter Set. MPS will furnish and install the meter set in accordance with the requirements of Section 600, Meters.

903.8 Underground Service Extension. Underground service to commercial centers and industrial parks will be arranged on an individual basis. In those cases where it is necessary to extend the MPS main distribution system into such centers or parks, the Customer may be charged for the extension an amount which reflects the unrecoverable cost of the underground facilities if the projected revenue from electric sales to the new Customers is uneconomical.

904 Transformer Clearances

Where pad-mounted transformers and equipment in pad-mounted enclosures are installed, the minimum clearances specified in Section 1000, Appendix 2, Exhibit 7, must be maintained. Fences, shrubbery, and trees may be installed by the Customer provided that the specified clearances are maintained, the grade is not altered, and the underground cables are not endangered.

905 Winter Installation

Underground cable installation at the Customer's request between November 1 and April 30 shall be subject to a winter installation charge.

906 Total Undergrounding

MPS does not install underground vaults, manholes, or submersible transformers. Electric services requiring the total undergrounding of facilities will be arranged for on an individual basis.

SECTION 1000

APPENDICES

Appendix 1 – Forms

- Residential Service Application
- Commercial Utility Service Application
- Dual-Heat Application/Contract

Appendix 2 – Tables and Diagrams

DUAL-FUEL PROGRAM

RESIDENTIAL APPLICATION



CUSTOMER INFORMATION (PLEASE PRINT)

NAME: _____ INSTALLATION ADDRESS: _____
ACCOUNT #: _____ CITY: _____ STATE: _____ ZIP: _____
MAILING ADDRESS: _____ TELEPHONE-HOME: _____
CITY: _____ STATE: _____ ZIP: _____ TELEPHONE -WORK: _____
HEATING CONTRACTOR: _____ ELECTRICAL CONTRACTOR: _____

DESCRIPTION OF PROPOSED DUAL-FUEL HEATING SYSTEM

Please check the box that best describes the primary heating system you plan to use:

<input type="checkbox"/> Electric boiler	<input type="checkbox"/> Electric thermal storage	<input type="checkbox"/> Electric radiant floor heat (electric cable)
<input type="checkbox"/> Electric forced air	<input type="checkbox"/> Electric baseboard	<input type="checkbox"/> Electric radiant floor heat (hydronic system)
<input type="checkbox"/> Other		

Please check the box that best describes the type of secondary heating system you plan to use:

<input type="checkbox"/> Forced air	<input type="checkbox"/> Boiler	<input type="checkbox"/> Radiant floor heat storage
<input type="checkbox"/> Electric storage unit	<input type="checkbox"/> Other	

What fuel will your secondary heating system use:

<input type="checkbox"/> Natural gas	<input type="checkbox"/> Fuel Oil	<input type="checkbox"/> Storage Heat (in floor or thermal storage unit)
<input type="checkbox"/> Propane	<input type="checkbox"/> Other	

WATER HEATING

ELECTRIC NATURAL GAS (PLEASE CHECK ONE)

If you have electric water heat, would you like MPS to control your water heater?

- Yes, I would like long-term water heating cycling. (Max: 8 hours of control per control period; dual-fuel rate applies).
- Yes, I would like short-term water heating cycling. (Max: 4 hours of control per control period; \$3.00 billing credit per month).
- No, I do not want MPS to control my water at this time.

CENTRAL AIR CONDITIONING

If you have central air conditioning, would you like MPS to control your air conditioner?

- Yes, I would central air conditioning cycling.
(Compressor cycled on/off for 12-minute periods during control period; dual-fuel rate applies)

(Continued on other side)

DUAL-FUEL PROGRAM

RESIDENTIAL APPLICATION CONTINUED



SIGNATURE

The undersigned has read and agrees to the Dual-Fuel Agreement and will follow and adhere to all MPS Electric Service Rules and Regulations.

APPLICANT: _____

DATE: _____

MPS OFFICE USE ONLY

The dual-fuel system, as described by the applicant meets MPS Dual-Fuel Program regulations. Approval of this application does not infer that the customers' dual-fuel system will be approved to receive the dual-fuel rate when MPS makes its final inspection. The customer and heating contractor are still responsible for the installation of the actual dual-fuel system and ensuring the secondary heating system is capable of heating the entire home during MPS control periods.

MPS REPRESENTATIVE: _____

DATE: _____

GUARANTY

TO BE SIGNED BY THE HEATING CONTRACTOR THAT INSTALLS YOUR SECONDARY HEATING SYSTEM

The undersigned acknowledges that the secondary heating system (described below) is capable of providing sufficient heat for this home during control periods when the electric heat is turned off by MPS. The undersigned has fully explained the secondary heating system capabilities to the homeowner.

The contractor further agrees to comply with MPS' Rules and Regulations regarding the Dual-Fuel Program and other controlled loads now in effect and as revised from time-to-time by MPS.

CUSTOMER NAME: _____

CUSTOMER SERVICE ADDRESS: _____

Please describe the secondary heating system installed at this address including the type of heat, the efficiency rating, and the rated British Thermal Units per hour (BTUH).

CONTRACTOR NAME: _____

COMPANY: _____

ADDRESS: _____

CITY: _____

STATE: _____

ZIP: _____

PHONE: _____

FAX: _____

CONTRACTOR SIGNATURE: _____

DATE: _____

DUAL-FUEL PROGRAM

COMMERCIAL APPLICATION



CUSTOMER INFORMATION (PLEASE PRINT)

BUSINESS NAME: _____	INSTALLATION ADDRESS: _____
ACCOUNT #: _____	CITY: _____ STATE: _____ ZIP: _____
MAILING ADDRESS: _____	CONTACT PERSON: _____
CITY: _____ STATE: _____ ZIP: _____	TELEPHONE: _____ EMAIL: _____
HEATING CONTRACTOR: _____	ELECTRICAL CONTRACTOR: _____

DESCRIPTION OF PROPOSED DUAL-FUEL HEATING SYSTEM

Please describe the primary heating system you plan to use (fuel, type, rated capacity):

Please describe the secondary heating system you plan to use (fuel, type, rated capacity):

Please describe the areas of the building that this heating system will serve:

SIGNATURE

The undersigned has read and agrees to the Dual-Fuel Agreement and will follow and adhere to all MPS Electric Service Rules and Regulations.

APPLICANT: _____ DATE: _____

MPS OFFICE USE ONLY

The dual-fuel system, as described by the customer in the application, meets MPS Dual-Fuel Program regulations. Approval of this application does not infer that the customer's dual-fuel system will be approved to receive the dual-fuel rate when MPS make its final inspection. The customer and heating contractor are still responsible for the installation of the actual dual-fuel system and ensuring the secondary heating system is capable of heating the entire business during MPS control periods.

MPS REPRESENTATIVE: _____ DATE: _____

(Continued on other side)

DUAL-FUEL PROGRAM

GUARANTY TO BE SIGNED BY THE HEATING CONTRACTOR THAT INSTALLS YOUR SECONDARY HEATING SYSTEM



The undersigned acknowledges that the secondary heating system (described below) is capable of providing sufficient heat for this home during control periods when the electric heat is turned off by MPS. The undersigned has fully explained the secondary heating system capabilities to the homeowner.

The contractor further agrees to comply with MPS' Rules and Regulations regarding the Dual-Fuel Program and other controlled loads now in effect and as revised from time-to-time by MPS.

CUSTOMER NAME:

CUSTOMER SERVICE ADDRESS:

Please describe the secondary heating system installed at this address including the type of heat, the efficiency rating, and the rated British Thermal Units per hour (BTUH).

CONTRACTOR NAME:

COMPANY:

ADDRESS:

CITY:

STATE:

ZIP:

PHONE:

FAX:

CONTRACTOR SIGNATURE:

DATE:

DUAL-FUEL PROGRAM

COMMERCIAL APPLICATION



In consideration of the availability to receive special dual-fuel rate reductions and other considerations, the receipt of which is hereby acknowledged, the Applicant agrees to install and maintain an approved dual-fuel heating system conforming to current Moorhead Public Service (MPS) Electric Service Rules and Regulations.

The primary heating system for the home or business shall be electric. The secondary heating system must utilize thermal storage or be fueled by natural gas, fuel oil, or propane. The secondary heating system must be capable of providing Applicant's total heating requirements.

The Applicant agrees to allow MPS to switch the Applicant to their secondary heating system without notice during peak electric demand periods. MPS will also control any other electric load or group of loads mutually agreed upon as defined in MPS Electric Service Rules and Regulations.

The Applicant agrees to allow MPS access to the Applicant's home or business to inspect the installation of the dual-fuel heating system and to periodically inspect the operation of the system.

The Applicant agrees to indemnify and hold MPS harmless for any damage related to the operation of the dual-fuel heating system and any other controlled loads, whether direct or indirect.

The Applicant agrees that any tampering or installations not conforming to MPS Electric Service Rules and Regulations shall be grounds for immediate removal from the dual-fuel rate. In event of such removal, all energy used between the last inspection date and the date of discovery of the tampering or installation error shall be billed at the highest current rate in effect. The Applicant hereby agrees to pay any charges so billed upon written notice from MPS.

The Applicant agrees that any and all incentives provided by MPS for participation in the Dual-Fuel Program must be claimed within three (3) months after the dual-fuel inspection. Failure to claim such incentives within the time provided shall result in their forfeiture.

The Applicant acknowledges that if the utility bill, including the loan repayment amount, is not paid in a timely manner, the Applicant's utility service may be disconnected as outlined in MPS' Policy on Collection of Past Due Accounts.

The Applicant further agrees to comply with the rules and regulations of MPS regarding the Dual-Fuel Program and other controlled loads now in effect and as revised from time-to-time by MPS.

EXHIBIT 1

TYPICAL UNDERGROUND RESIDENTIAL METERING ARRANGEMENT UP TO AND INCLUDING 200 AMP, 120/240 VOLT

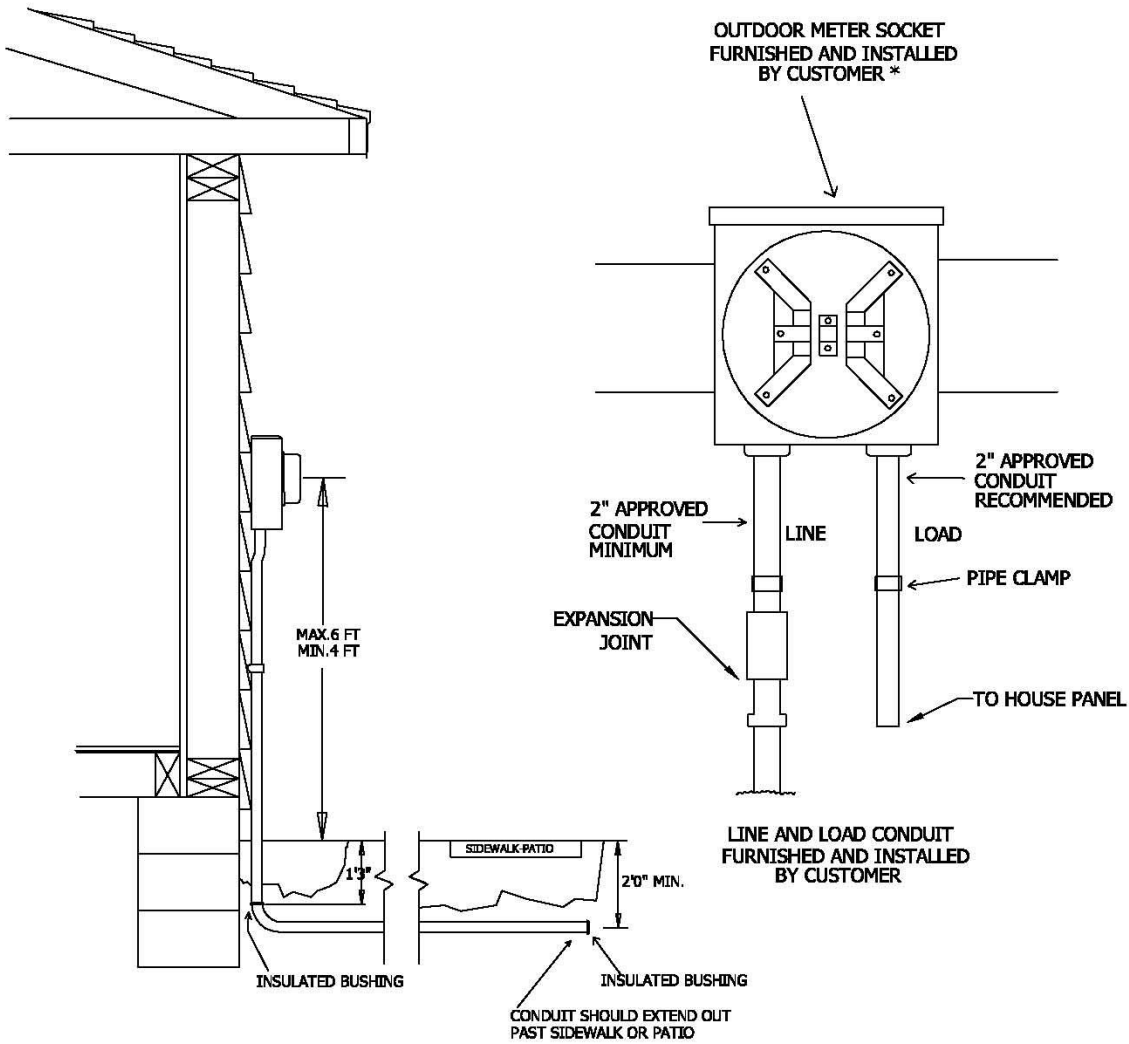

***METER SOCKETS SHALL BE RINGLESS
WITH LEVER BYPASS AND BE RATED AT
200 AMP MINIMUM**

RULES AND REGULATIONS				
EXHIBIT 1				
REQ. #	ED087	Date	NA	NA
DESCRIPTION	CDS	REVISION	RBS	02/05/10
MOORHEAD PUBLIC SERVICE		600 CENTER AVENUE, 802 PM MOORHEAD, MINNESOTA 56501 TEL: 833-626-5438 FAX: 833-6158		
		mrs@moorheadps.com		

EXHIBIT 2

TYPICAL MOBILE HOME METERING ARRANGEMENT

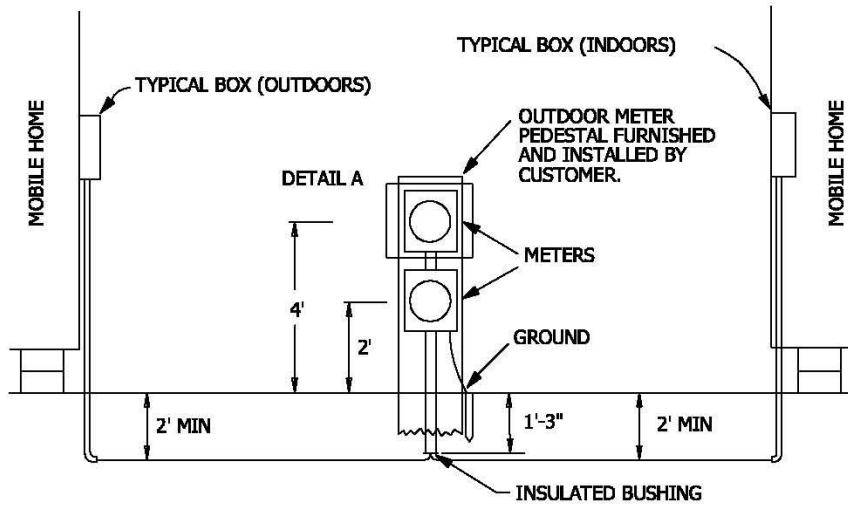

1. METERS ARE TO BE PERMANENTLY LABELED.
2. METERS ARE TO FACE TOWARDS STREET.
3. SERVICE LATERAL FROM METER TO MOBILE HOME IS RESPONSIBILITY OF CUSTOMER.

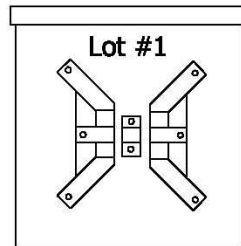

DETAIL "A"
Meter socket with cover removed

RULES AND REGULATIONS					
EXHIBIT 2					
Doc #	ED087	Rev	NA	NA	NA
		Issued	CDS	RBS	02/05/10
		800 CENTER AVENUE, BOX 775 MOORHEAD, MINNESOTA 56501 (218) 835-4400 Fax: 218-835-4158 mps@mpsall.biz.com			

EXHIBIT 3

TYPICAL MULTIPLE METERING ARRANGEMENT

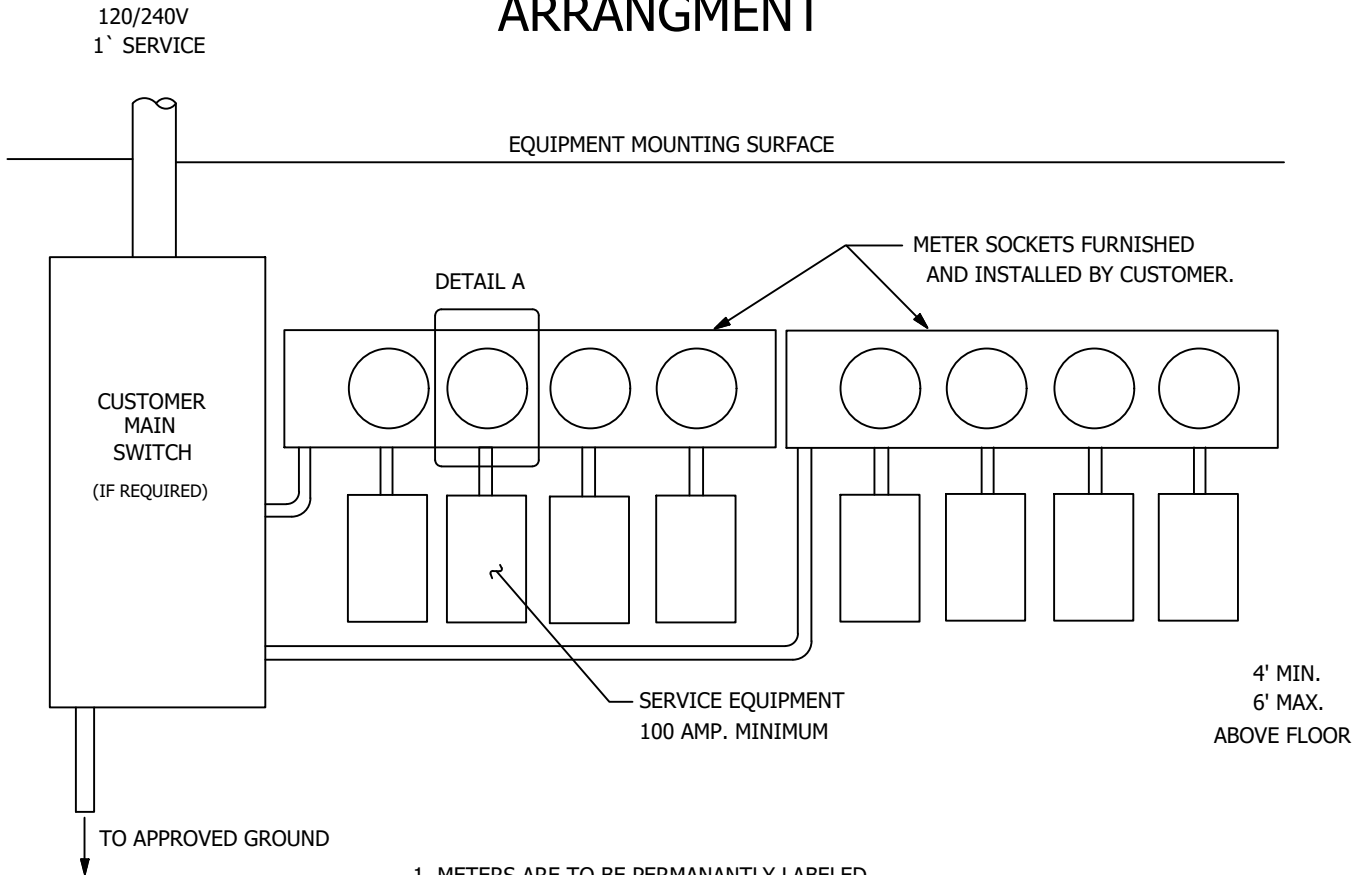

1. METERS ARE TO BE PERMANANTLY LABELED.
2. METERS MUST HAVE INDIVIDUAL LOCK-OFF CAPABILITY.
3. METERS MUST BE ACCESSIBLE TO M.P.S. AND TO CUSTOMERS.

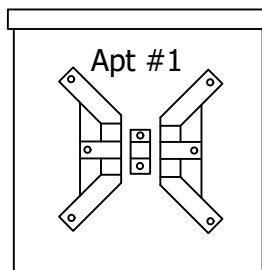

DETAIL "A"
Meter socket with cover removed

RULES AND REGULATIONS					
EXHIBIT 3					
DWG #:	E0087	Scale:	NA	NA	NA
		Design by:	CDS	Reviewed by:	TJM
		Drawn by:		Date:	10/10/25
		500 CENTER AVENUE, BOX 779 MOORHEAD, MINNESOTA 56561 (218) 299-5400 Fax: 299-5193 mps@mpsutility.com			

EXHIBIT 4

SECONDARY SERVICE DROP CLEARANCES

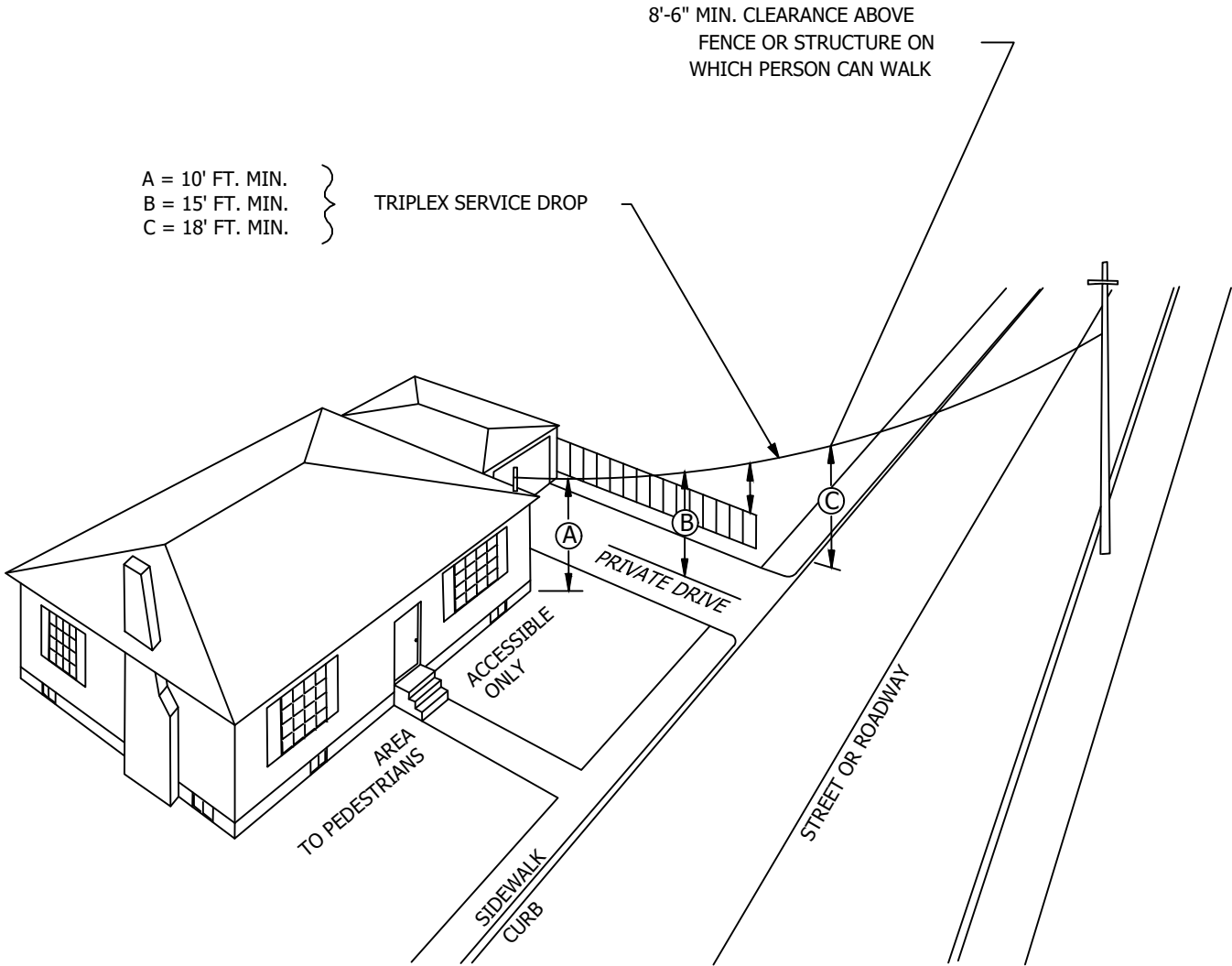

RULES AND REGULATIONS					
EXHIBIT 4					
DWG #:	E0087	Scale:	NA	OR	NA
Design by:	CDS	Issued by:	TJM	Date:	10/10/25
		500 CENTER AVENUE, BOX 779 MOORHEAD, MINNESOTA 56561 (218) 299-5400 Fax: 299-5193 mps@mpservice.com			

TYPICAL RESIDENTIAL OVERHEAD
INSTALLATION

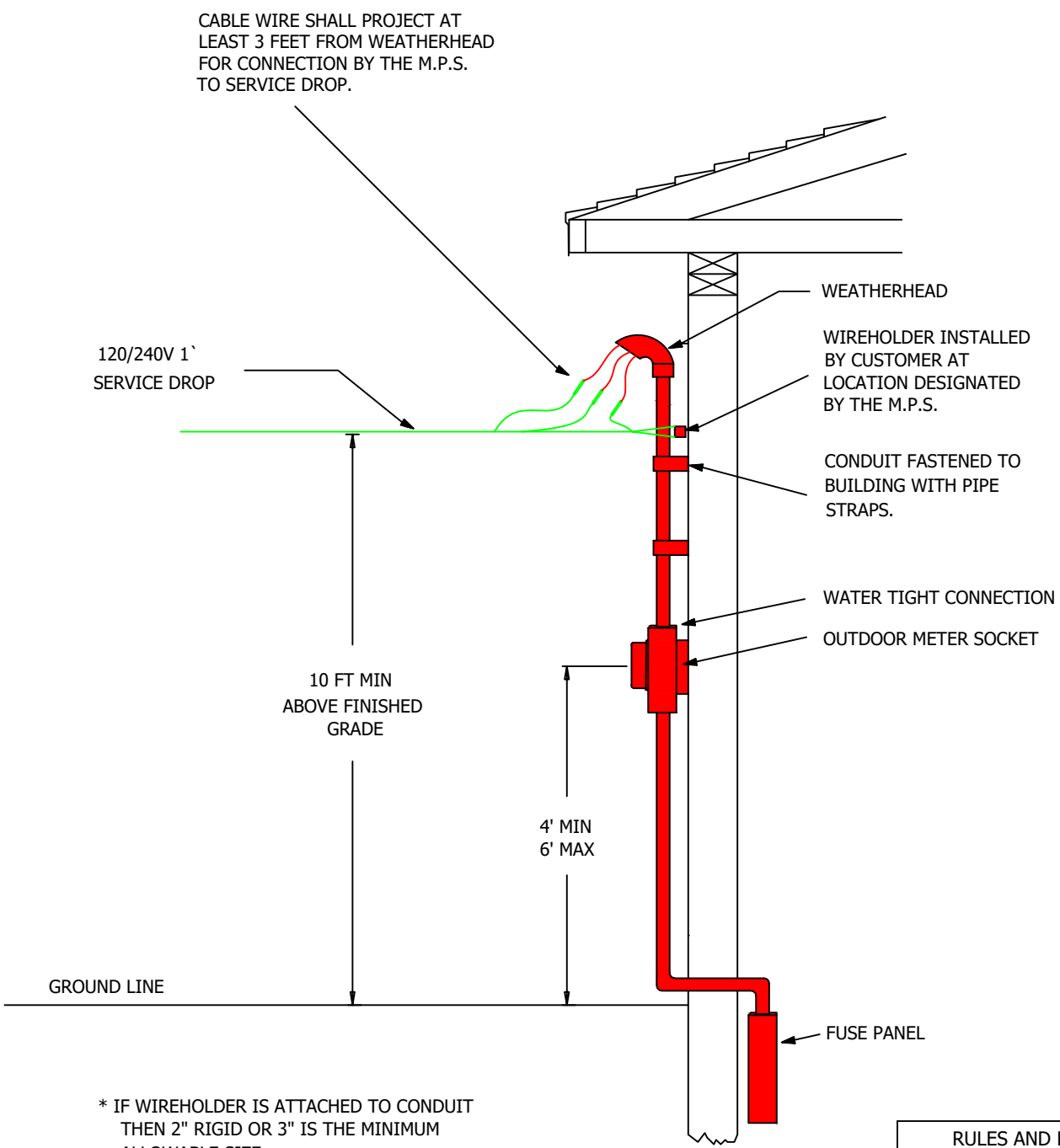

* IF WIREHOLDER IS ATTACHED TO CONDUIT THEN 2" RIGID OR 3" IS THE MINIMUM ALLOWABLE SIZE

Last updated: 02/17/2026
v7.0

RULES AND REGULATIONS					
EXHIBIT 5					
DWG #:	E0087	Scale:	NA	NA	0'
Design by:	CDS	Drawn by:	TJM	Revised by:	NA
Project #:		Sheet #:		Date:	10/10/25
		500 CENTER AVENUE, BOX 779 MOORHEAD, MINNESOTA 56561 (218) 299-5400 Fax: 299-5193 mps@mpsuility.com			

TYPICAL RESIDENTIAL SERVICE MAST

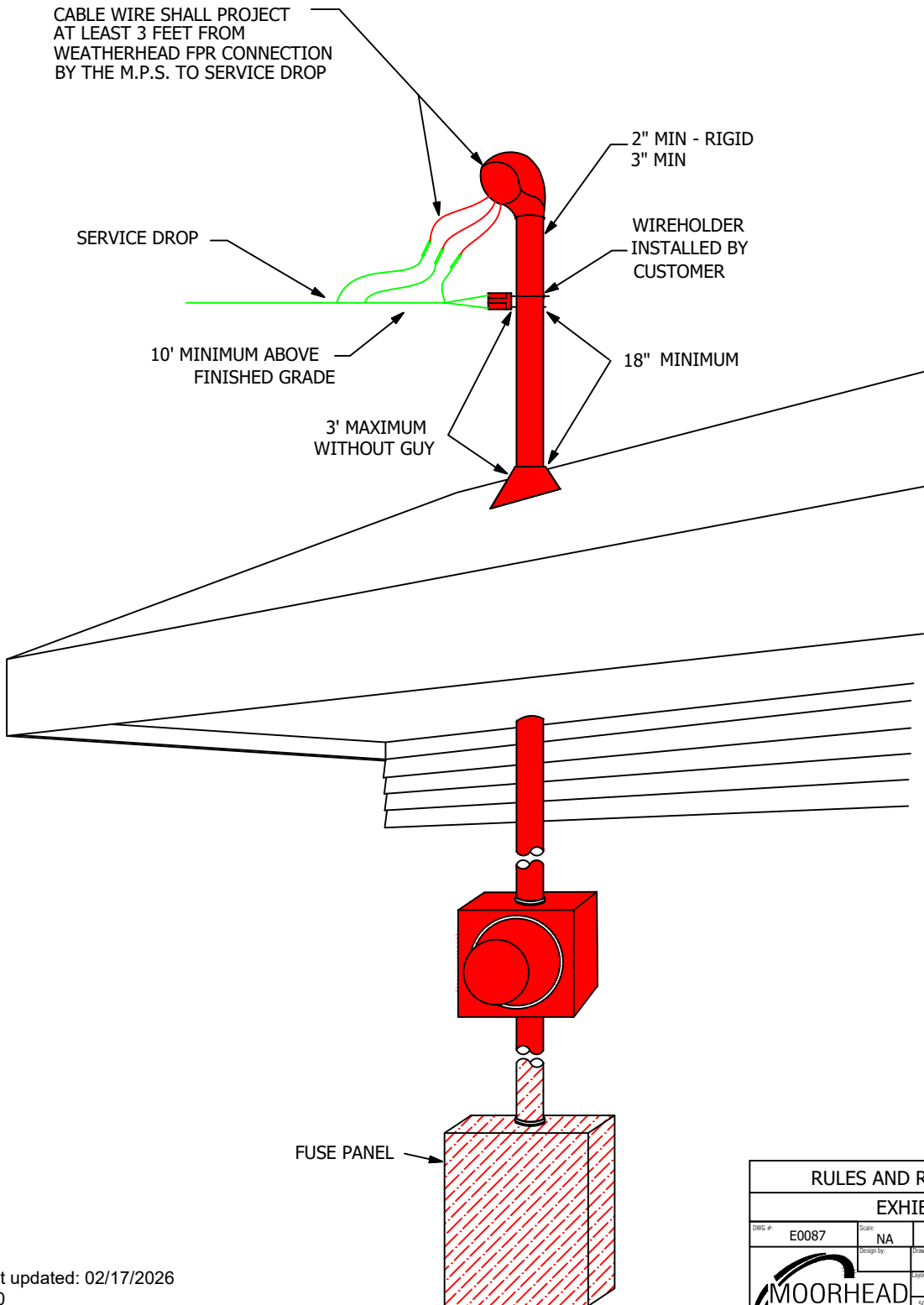

Last updated: 02/17/2026
v7.0

RULES AND REGULATIONS					
EXHIBIT 6					
DWG #:	E0087	Scale:	NA	Sheet #:	0
Drawn by:	CDS	Checked by:	TJM	Date:	10/13/25
Project #:		Sheet #:		Project #:	
		500 CENTER AVENUE, BOX 779 MOORHEAD, MINNESOTA 56561 (218)299-5400 Fax: 299-5193 mps@mpeutility.com			

EXHIBIT 7 LOCATION OF PAD-MOUNTED TRANSFORMERS NEAR BUILDINGS

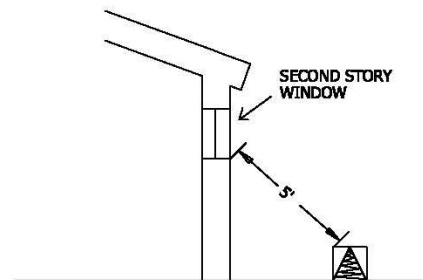
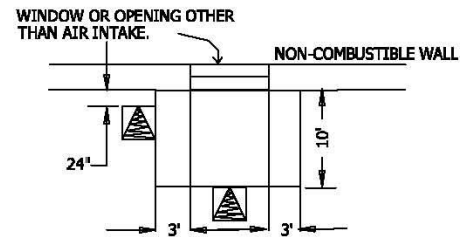
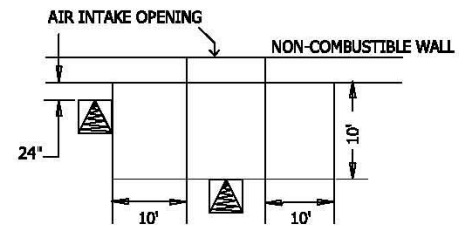
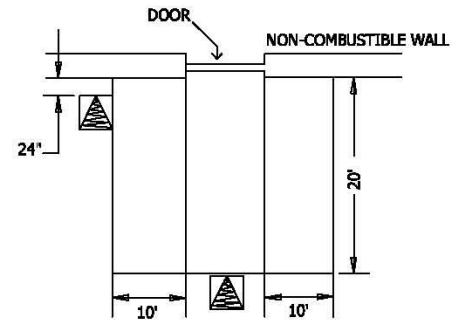

RULES AND REGULATIONS					
EXHIBIT 7-TRANSFORMER LOCATIONS					
Doc #:	E0087	Scale:	NA	NA	0'
Author:	CEC	Reviewer:	RBS	Date:	02/05/10
		800 CENTER AVENUE, BOX 770 MOORHEAD, MINNESOTA 56501 (218)223-5400 Fax: 218-4198			
		mps@mpsi.com			

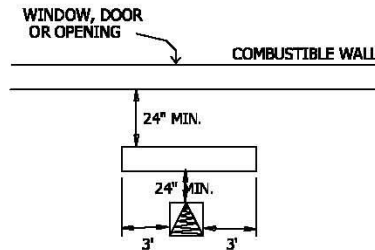
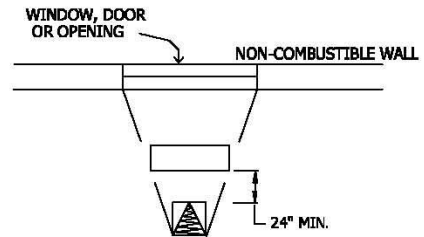
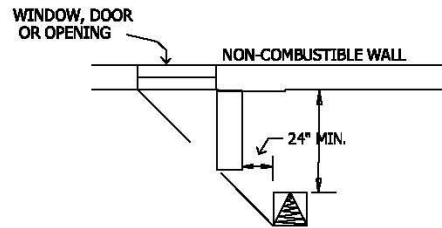
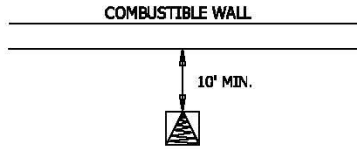



RULES AND REGULATIONS				
EXHIBIT 7-TRANSFORMER LOCATIONS				
PROJECT:	ED087	DATE:	NA	DATE:
DESIGNED BY:	CEC	DRAWN BY:	RBS	DATE:
DATE:		PROJECT:		02/05/10
		300 CENTER AVENUE, BOX 719 MOORHEAD, MINNESOTA 56501 (218) 838-6400 Fax: 218-838-6165		
		www.mps.com		

EXHIBIT 8

DUAL-HEATING METERING

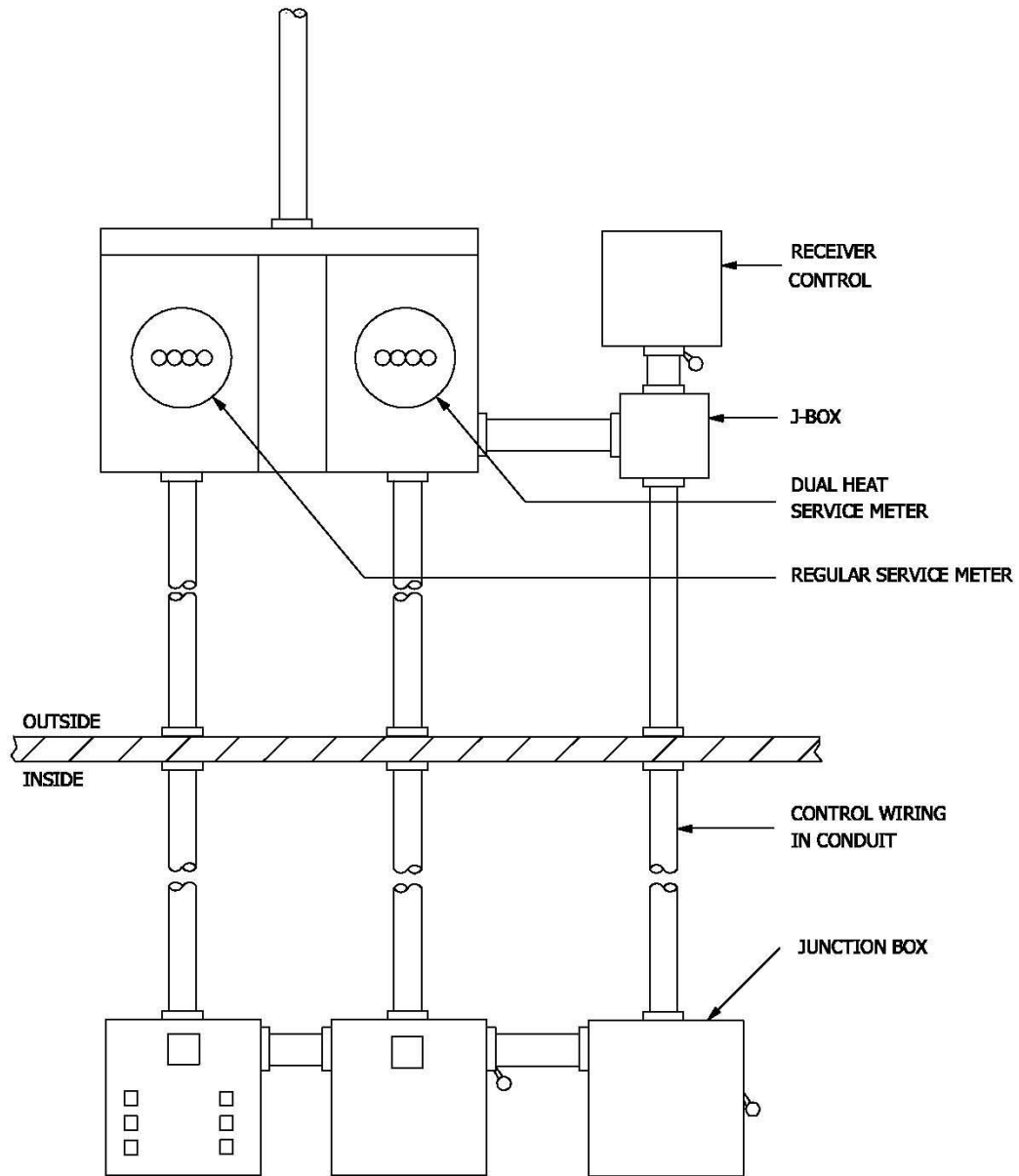
TYPICAL DUAL FUEL SERVICE ARRANGEMENT



RULES AND REGULATIONS				
EXHIBIT 8 - DUAL FUEL SERVICE				
Doc #	Size	Version	Revised by	Date
E0087	NA	NA	NA	NA
Created by	CDS	Revised by	RBS	02/05/10
Drawn by	NA	Checked by	NA	NA
				
330 CENTER AVENUE, BOX 176 MOORHEAD, MINNESOTA 56501 (763) 835-5400 Fax: 835-4108 mps@moorheadps.com				

TYPICAL RECEIVER POWER WIRING DIAGRAM

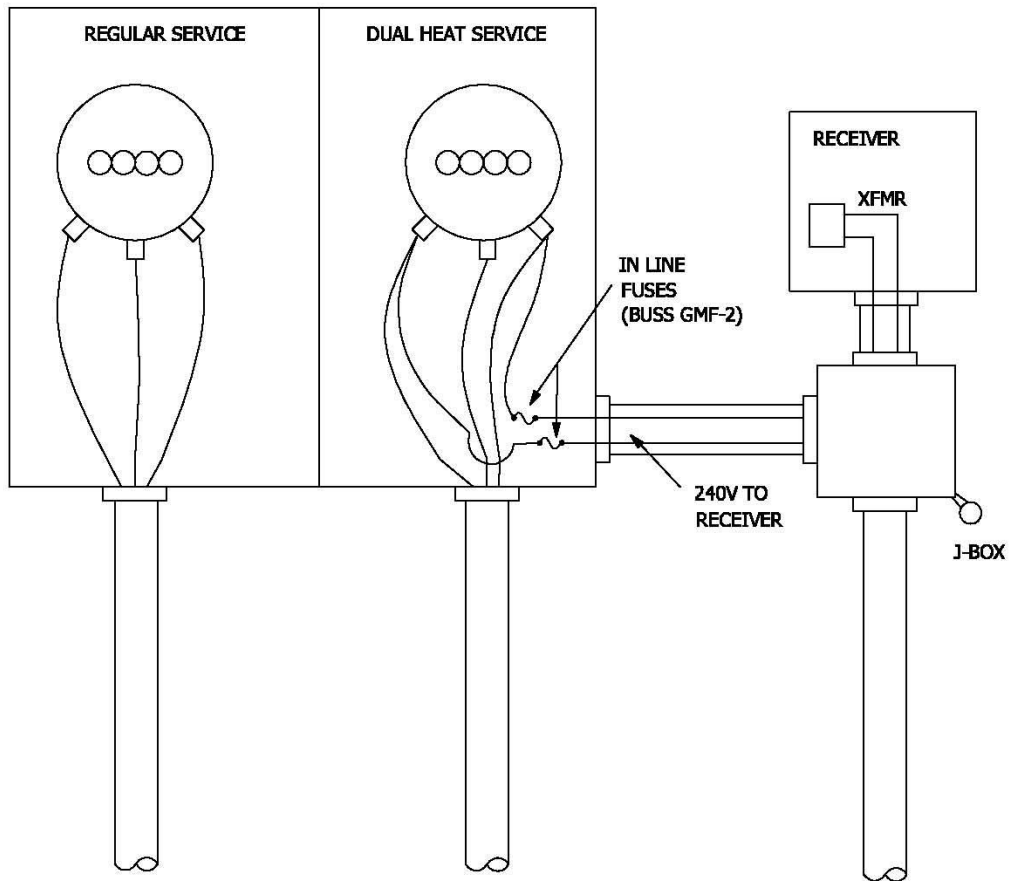

RULES AND REGULATIONS					
EXHIBIT 8-RECEIVER WIRING DIAGRAM					
ENG.#:	ED087	Scale:	NA	NA	0'
Design by:		Checked by:	CDS	Revised by:	RBS
DATE:		DATE:		DATE:	02/05/10
			300 CENTER AVENUE, BOX 770 MOORHEAD, MINNESOTA, 56501 (218)236-5400 Fax: (218) 236-6166		
			rps@moorheadps.com		

WATER HEATER CONTROL - LONG TERM

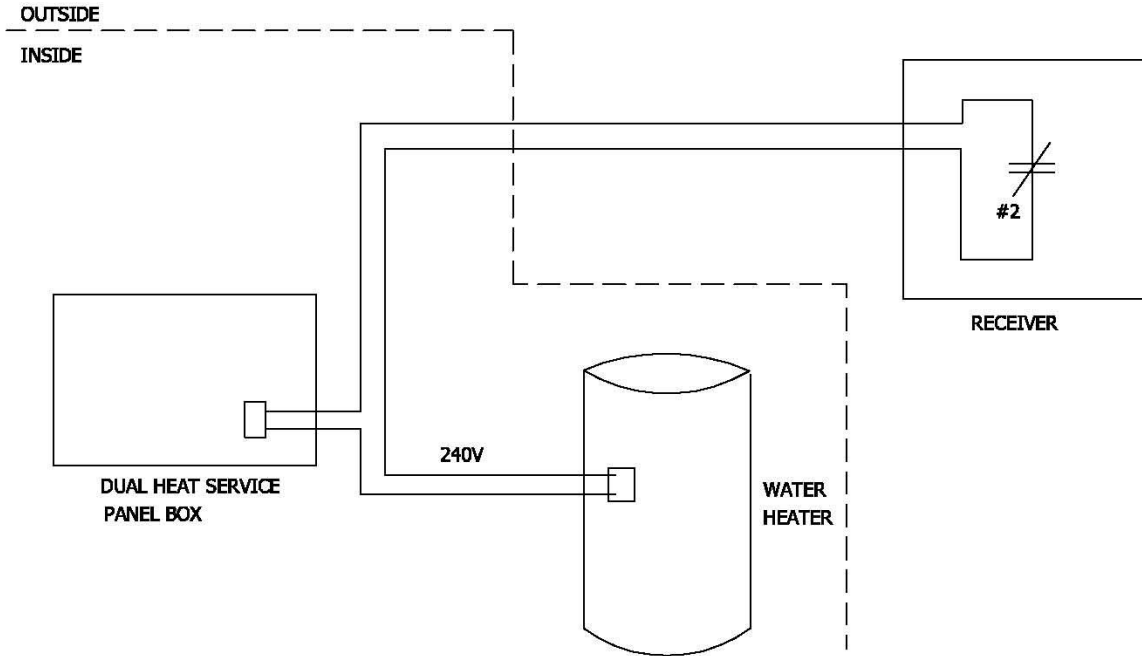

WATER HEATER CONTROL - SHORT TERM

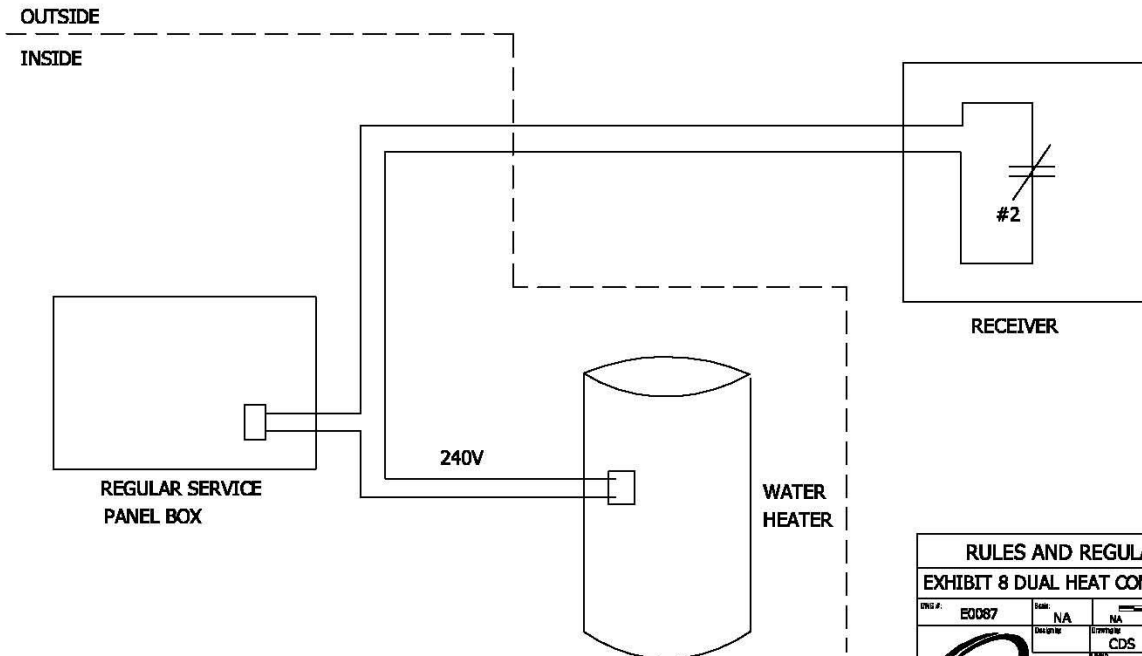

RULES AND REGULATIONS				
EXHIBIT 8 DUAL HEAT CONTROL SCHEME				
ENG #:	E0087	Rev:	NA	0
Design:	CDS	Form:	RBS	02/05/10
Drawn:		Checked:		
				
400 CENTER AVENUE, BOX 770 MOORHEAD, MINNESOTA 56501 (763) 836-6340 Fax: (763) 836-3103				
mops@mnpower.com				

DUAL HEAT RECEIVER WIRING SCHEME

FUNCTION 2 IS FOR
WATER HEATER CONTROL

RECEIVER SUPPLIED BY MPS

FUNCTION 1 IS FOR HEATING
CONTROL IN WINTER AND FOR AIR
CONDITIONING CONTROL IN
SUMMER.
CONTACTS ARE RATED AT 10 AMPS
AND 120 VOLTS.
ADDITIONAL CONTROL RELAYS MAY
BE NEEDED.

TO LOAD SIDE OF
DUAL HEAT METER
THRU IN LINE FUSES

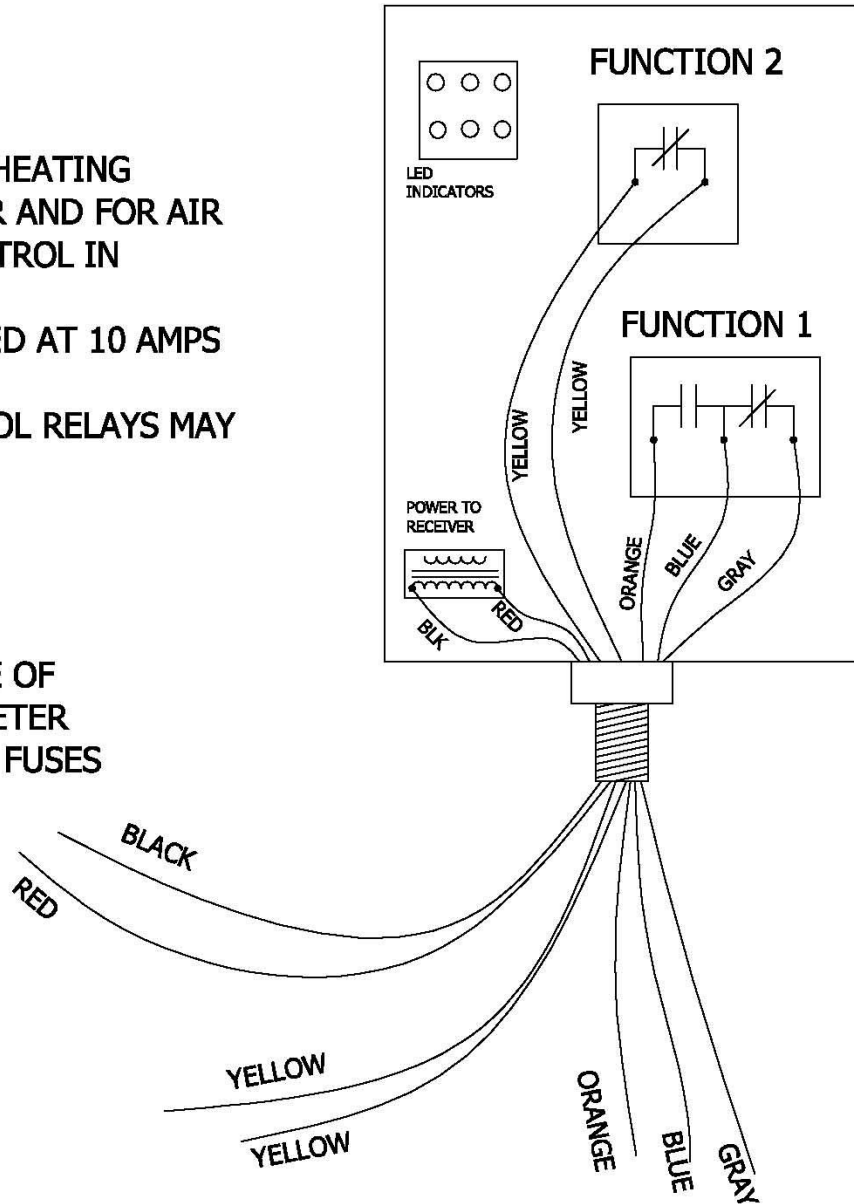

RULES AND REGULATIONS					
EXHIBIT 8 DUAL HEAT CONTROL SCHEME					
Doc#:	EG087	Rev:	NA	NA	0
Design:	CDS	Revised by:	RBS	Date:	02/05/10
Drawn:		Checked:		By:	
			MOORHEAD PUBLIC SERVICE 400 CENTER AVENUE, BOX 170 MOORHEAD, MINNESOTA 56501 (763) 835-3400 Fax: 833-8182 mps@moorheadmn.com		